

WWW.JJTOOLS.CO.KR
Made in Korea

 제이제이툴스(주)
JJ TOOLS Co.,Ltd.
(구) 장진공구

G series



Carbide End Mills INDEX

시리즈 Series	특징 Hardness	주문 번호 EDP. NO	형상 Appearance	날 수 Flutes	분류 Type	쪽 Page
	프리하든강 탄소강 금형강 HRc ~52	2HRBG		2F	리브 볼 Rib Ball End Mills	93
		2HSBG		2F	짧은 길이 볼 Short Length Ball End Mills	95
		2HCBG		2F	표준 길이 볼 Standard Length Ball End Mills	96
		2HREG		2F	리브 엔드밀 Rib End Mills	97
		4HREG		4F	리브 엔드밀 Rib End Mills	99
		2HCEG		2F	표준 길이 엔드밀 Standard Length End Mills	100
		2LEMG		2F	긴 길이 엔드밀 Long Length End Mills	101
		4HCEG		4F	표준 길이 엔드밀 Standard Length End Mills	102
		4LEMG		4F	긴 길이 엔드밀 Long Length End Mills	103
		4HEMG		4F	45° 헬릭스 엔드밀 45° Helix End Mills	104
		2CREG		2F	리브 코너 레디우스 Rib Corner Radius	105
		4CREG		4F	리브 코너 레디우스 Rib Corner Radius	108
		2NCRG		2F	코너 레디우스 Corner Radius End Mills	111
		4NCRG		4F	코너 레디우스 Corner Radius End Mills	113
	고경도·일반강 황삭 가공 HRc ~50	3&4ROUG		3&4	라핑 엔드밀 Roughing End Mills	115
		3&4HROUG		3&4	45° 헬릭스 파인피치형 라핑 45° Helix Fine Pitch Roughing	116

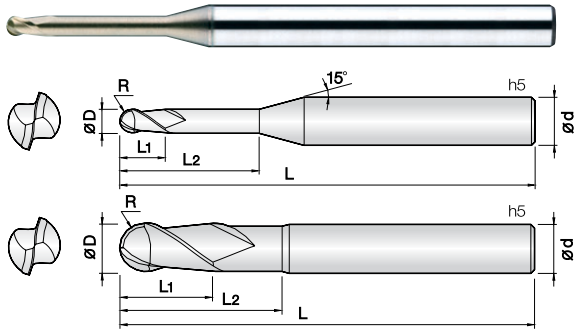

• 중저경도강(HRc52이하), 프리하드강 계열, 탄소강, 금형강 등 다양한 피삭재 가공

• JCRO 코팅 처리하여 넓은 영역의 피삭재 가공에 적합합니다.

• 고정밀 공차 적용으로 초정밀 가공에 적합합니다.

• 항절력이 높은 미립자 초경합금(0.5 μ m)을 채택, 엔드밀의 파손을 최소화 하였습니다.

• Endmills for various work materials(~HRc52), pre-hardened steel, carbon steel, mold steel.

• Optimum for various work materials by JCRO coating.

• High precise edge tolerance.

• Minimize fracturing by high TRS fine(0.5 μ m) WC grade.



D Size	D Tolerance
Ø0.1	+0 ~ -0.005mm
Ø0.2 ~ 5	+0 ~ -0.01mm
Ø6 ~ 12	-0.005 ~ -0.015mm

단위 : mm

Order Number	날경 Diameter R x D	날장 Length of cut L1	유효장 Effective Length L2	전장 Overall Length L	샙크 Shank Dia d	비고	Order Number	날경 Diameter R x D	날장 Length of cut L1	유효장 Effective Length L2	전장 Overall Length L	샙크 Shank Dia d	비고
2HRBG 001 003 S04	0.05R X 0.1	0.3	-	40	4		2HRBG 008 060 S04	0.4R X 0.8	0.9	6	45	4	
2HRBG 001 005 S04	0.05R X 0.1	0.5	-	40	4		2HRBG 008 080 S04	0.4R X 0.8	0.9	8	45	4	
2HRBG 002 005 S04	0.1R X 0.2	0.2	0.5	40	4		2HRBG 008 100 S04	0.4R X 0.8	0.9	10	45	4	
2HRBG 002 010 S04	0.1R X 0.2	0.2	1	40	4		2HRBG 008 120 S04	0.4R X 0.8	0.9	12	45	4	
2HRBG 002 015 S04	0.1R X 0.2	0.2	1.5	40	4		2HRBG 008 140 S04	0.4R X 0.8	0.9	14	45	4	
2HRBG 002 020 S04	0.1R X 0.2	0.2	2	40	4		2HRBG 008 160 S04	0.4R X 0.8	0.9	16	45	4	
2HRBG 003 010 S04	0.15R X 0.3	0.3	1	40	4		2HRBG 009 040 S04	0.45R X 0.9	1	4	45	4	
2HRBG 003 015 S04	0.15R X 0.3	0.3	1.5	40	4		2HRBG 010 020 S04	0.5R X 1	1.2	2	45	4	
2HRBG 003 020 S04	0.15R X 0.3	0.3	2	40	4		2HRBG 010 020 S06	0.5R X 1	1.2	2	45	6	
2HRBG 003 030 S04	0.15R X 0.3	0.3	3	40	4		2HRBG 010 030 S04	0.5R X 1	1.2	3	45	4	
2HRBG 003 040 S04	0.15R X 0.3	0.3	4	40	4		2HRBG 010 030 S06	0.5R X 1	1.2	3	45	6	
2HRBG 003 050 S04	0.15R X 0.3	0.3	5	40	4		2HRBG 010 040 S04	0.5R X 1	1.2	4	45	4	
2HRBG 004 010 S04	0.2R X 0.4	0.5	1	40	4		2HRBG 010 040 S06	0.5R X 1	1.2	4	45	6	
2HRBG 004 020 S04	0.2R X 0.4	0.5	2	40	4		2HRBG 010 050 S04	0.5R X 1	1.2	5	45	4	
2HRBG 004 030 S04	0.2R X 0.4	0.5	3	40	4		2HRBG 010 050 S06	0.5R X 1	1.2	5	45	6	
2HRBG 004040 S04	0.2R X 0.4	0.5	4	40	4		2HRBG 010 060 S04	0.5R X 1	1.2	6	45	4	
2HRBG 004 050 S04	0.2R X 0.4	0.5	5	40	4		2HRBG 010 060 S06	0.5R X 1	1.2	6	45	6	
2HRBG 004 060 S04	0.2R X 0.4	0.5	6	40	4		2HRBG 010 080 S04	0.5R X 1	1.2	8	45	4	
2HRBG 004 080 S04	0.2R X 0.4	0.5	8	40	4		2HRBG 010 080 S06	0.5R X 1	1.2	8	45	6	
2HRBG 004 100 S04	0.2R X 0.4	0.5	10	40	4		2HRBG 010 100 S04	0.5R X 1	1.2	10	50	4	
2HRBG 005 010 S04	0.25R X 0.5	0.6	1	45	4		2HRBG 010 100 S06	0.5R X 1	1.2	10	50	6	
2HRBG 005 020 S04	0.25R X 0.5	0.6	2	45	4		2HRBG 010 120 S04	0.5R X 1	1.2	12	50	4	
2HRBG 005 030 S04	0.25R X 0.5	0.6	3	45	4		2HRBG 010 120 S06	0.5R X 1	1.2	12	50	6	
2HRBG 005 040 S04	0.25R X 0.5	0.6	4	45	4		2HRBG 010 140 S04	0.5R X 1	1.2	14	50	4	
2HRBG 005 050 S04	0.25R X 0.5	0.6	5	45	4		2HRBG 010 140 S06	0.5R X 1	1.2	14	50	6	
2HRBG 005 060 S04	0.25R X 0.5	0.6	6	45	4		2HRBG 010 160 S04	0.5R X 1	1.2	16	50	4	
2HRBG 005 080 S04	0.25R X 0.5	0.6	8	45	4		2HRBG 010 160 S06	0.5R X 1	1.2	16	55	6	
2HRBG 005 100 S04	0.25R X 0.5	0.6	10	45	4		2HRBG 010 180 S04	0.5R X 1	1.2	18	50	4	
2HRBG 005 120 S04	0.25R X 0.5	0.6	12	45	4		2HRBG 010 180 S06	0.5R X 1	1.2	18	60	6	
2HRBG 005 140 S04	0.25R X 0.5	0.6	14	45	4		2HRBG 010 200 S04	0.5R X 1	1.2	20	50	4	
2HRBG 006 010 S04	0.3R X 0.6	0.7	1	45	4		2HRBG 010 200 S06	0.5R X 1	1.2	20	60	6	
2HRBG 006 020 S04	0.3R X 0.6	0.7	2	45	4		2HRBG 010 220 S04	0.5R X 1	1.2	22	60	4	
2HRBG 006 030 S04	0.3R X 0.6	0.7	3	45	4		2HRBG 010 220 S06	0.5R X 1	1.2	22	65	6	
2HRBG 006 040 S04	0.3R X 0.6	0.7	4	45	4		2HRBG 010 250 S04	0.5R X 1	1.2	25	60	4	
2HRBG 006 050 S04	0.3R X 0.6	0.7	5	45	4		2HRBG 012 040 S04	0.6R X 1.2	1.4	4	45	4	
2HRBG 006 060 S04	0.3R X 0.6	0.7	6	45	4		2HRBG 012 040 S06	0.6R X 1.2	1.4	4	45	6	
2HRBG 006 080 S04	0.3R X 0.6	0.7	8	45	4		2HRBG 012 060 S04	0.6R X 1.2	1.4	6	45	4	
2HRBG 006 100 S04	0.3R X 0.6	0.7	10	45	4		2HRBG 012 060 S06	0.6R X 1.2	1.4	6	45	6	
2HRBG 006 120 S04	0.3R X 0.6	0.7	12	45	4		2HRBG 012 080 S04	0.6R X 1.2	1.4	8	45	4	
2HRBG 006 140 S04	0.3R X 0.6	0.7	14	45	4		2HRBG 012 080 S06	0.6R X 1.2	1.4	8	45	6	
2HRBG 006 160 S04	0.3R X 0.6	0.7	16	45	4		2HRBG 012 100 S04	0.6R X 1.2	1.4	10	50	4	
2HRBG 007 020 S04	0.35R X 0.7	0.8	2	45	4		2HRBG 012 100 S06	0.6R X 1.2	1.4	10	50	6	
2HRBG 007 040 S04	0.35R X 0.7	0.8	4	45	4		2HRBG 012 120 S04	0.6R X 1.2	1.4	12	50	4	
2HRBG 007 080 S04	0.35R X 0.7	0.8	8	45	4		2HRBG 012 120 S06	0.6R X 1.2	1.4	12	50	6	
2HRBG 007 100 S04	0.35R X 0.7	0.8	10	45	4		2HRBG 012 160 S04	0.6R X 1.2	1.4	16	50	4	
2HRBG 007 120 S04	0.35R X 0.7	0.8	12	45	4		2HRBG 012 160 S06	0.6R X 1.2	1.4	16	55	6	
2HRBG 008 020 S04	0.4R X 0.8	0.9	2	45	4		2HRBG 012 200 S04	0.6R X 1.2	1.4	20	50	4	
2HRBG 008 040 S04	0.4R X 0.8	0.9	4	45	4		2HRBG 012 200 S06	0.6R X 1.2	1.4	20	60	6	

단위 : mm

Order Number	날경 Diameter R x D	날장 Length of cut L1	유효장 Effective Length L2	전장 Overall Length L	샙크 Shank Dia d	비고	Order Number	날경 Diameter R x D	날장 Length of cut L1	유효장 Effective Length L2	전장 Overall Length L	샙크 Shank Dia d	비고
2HRBG 012 240 S04	0.6R X 1.2	1.4	24	60	4		2HRBG 020 250 S04	1R X 2	2.4	25	60	4	
2HRBG 012 240 S06	0.6R X 1.2	1.4	24	65	6		2HRBG 020 250 S06	1R X 2	2.4	25	65	6	
2HRBG 014 060 S04	0.7R X 1.4	1.6	6	45	4		2HRBG 020 300 S04	1R X 2	2.4	30	70	4	
2HRBG 014 080 S04	0.7R X 1.4	1.6	8	45	4		2HRBG 020 300 S06	1R X 2	2.4	30	70	6	
2HRBG 014 120 S04	0.7R X 1.4	1.6	12	50	4		2HRBG 020 350 S04	1R X 2	2.4	35	70	4	
2HRBG 014 160 S04	0.7R X 1.4	1.6	16	50	4		2HRBG 020 350 S06	1R X 2	2.4	35	75	6	
2HRBG 015 030 S04	0.75R X 1.5	1.8	3	45	4		2HRBG 020 400 S04	1R X 2	2.4	40	80	4	
2HRBG 015 030 S06	0.75R X 1.5	1.8	3	45	6		2HRBG 020 400 S06	1R X 2	2.4	40	80	6	
2HRBG 015 040 S04	0.75R X 1.5	1.8	4	45	4		2HRBG 020 450 S04	1R X 2	2.4	45	80	4	
2HRBG 015 040 S06	0.75R X 1.5	1.8	4	45	6		2HRBG 025 080 S04	1.25R X 2.5	3	8	45	4	
2HRBG 015 060 S04	0.75R X 1.5	1.8	6	45	4		2HRBG 025 100 S04	1.25R X 2.5	3	10	50	4	
2HRBG 015 060 S06	0.75R X 1.5	1.8	6	45	6		2HRBG 025 160 S04	1.25R X 2.5	3	16	50	4	
2HRBG 015 080 S04	0.75R X 1.5	1.8	8	45	4		2HRBG 025 200 S04	1.25R X 2.5	3	20	50	4	
2HRBG 015 080 S06	0.75R X 1.5	1.8	8	45	6		2HRBG 025 250 S04	1.25R X 2.5	3	25	60	4	
2HRBG 015 100 S04	0.75R X 1.5	1.8	10	50	4		2HRBG 025 300 S04	1.25R X 2.5	3	30	70	4	
2HRBG 015 100 S06	0.75R X 1.5	1.8	10	50	6		2HRBG 025 350 S04	1.25R X 2.5	3	35	70	4	
2HRBG 015 120 S04	0.75R X 1.5	1.8	12	50	4		2HRBG 030 060 S06	1.5R X 3	3.6	6	45	6	
2HRBG 015 120 S06	0.75R X 1.5	1.8	12	50	6		2HRBG 030 080 S06	1.5R X 3	3.6	8	45	6	
2HRBG 015 140 S04	0.75R X 1.5	1.8	14	50	4		2HRBG 030 100 S06	1.5R X 3	3.6	10	50	6	
2HRBG 015 140 S06	0.75R X 1.5	1.8	14	50	6		2HRBG 030 120 S06	1.5R X 3	3.6	12	50	6	
2HRBG 015 160 S04	0.75R X 1.5	1.8	16	50	4		2HRBG 030 160 S06	1.5R X 3	3.6	16	55	6	
2HRBG 015 160 S06	0.75R X 1.5	1.8	16	55	6		2HRBG 030 200 S06	1.5R X 3	3.6	20	60	6	
2HRBG 015 180 S04	0.75R X 1.5	1.8	18	50	4		2HRBG 030 250 S06	1.5R X 3	3.6	25	65	6	
2HRBG 015 180 S06	0.75R X 1.5	1.8	18	60	6		2HRBG 030 300 S06	1.5R X 3	3.6	30	70	6	
2HRBG 015 200 S04	0.75R X 1.5	1.8	20	50	4		2HRBG 030 350 S06	1.5R X 3	3.6	35	75	6	
2HRBG 015 200 S06	0.75R X 1.5	1.8	20	60	6		2HRBG 030 400 S06	1.5R X 3	3.6	40	80	6	
2HRBG 015 220 S04	0.75R X 1.5	1.8	22	60	4		2HRBG 030 450 S06	1.5R X 3	3.6	45	90	6	
2HRBG 015 220 S06	0.75R X 1.5	1.8	22	65	6		2HRBG 030 500 S06	1.5R X 3	3.6	50	100	6	
2HRBG 015 250 S04	0.75R X 1.5	1.8	25	60	4		2HRBG 030 600 S06	1.5R X 3	3.6	60	100	6	
2HRBG 015 250 S06	0.75R X 1.5	1.8	25	65	6		2HRBG 040 080 S06	2R X 4	4.8	8	45	6	
2HRBG 015 300 S04	0.75R X 1.5	1.8	30	70	4		2HRBG 040 100 S06	2R X 4	4.8	10	50	6	
2HRBG 015 300 S06	0.75R X 1.5	1.8	30	70	6		2HRBG 040 120 S06	2R X 4	4.8	12	50	6	
2HRBG 015 350 S04	0.75R X 1.5	1.8	35	70	4		2HRBG 040 160 S06	2R X 4	4.8	16	55	6	
2HRBG 016 060 S04	0.8R X 1.6	1.9	6	45	4		2HRBG 040 200 S06	2R X 4	4.8	20	60	6	
2HRBG 016 080 S04	0.8R X 1.6	1.9	8	45	4		2HRBG 040 250 S06	2R X 4	4.8	25	65	6	
2HRBG 016 120 S04	0.8R X 1.6	1.9	12	50	4		2HRBG 040 300 S06	2R X 4	4.8	30	70	6	
2HRBG 016 160 S04	0.8R X 1.6	1.9	16	50	4		2HRBG 040 350 S06	2R X 4	4.8	35	75	6	
2HRBG 016 200 S04	0.8R X 1.6	1.9	20	50	4		2HRBG 040 400 S06	2R X 4	4.8	40	80	6	
2HRBG 018 060 S04	0.9R X 1.8	2.1	6	45	4		2HRBG 040 450 S06	2R X 4	4.8	45	90	6	
2HRBG 018 080 S04	0.9R X 1.8	2.1	8	45	4		2HRBG 040 500 S06	2R X 4	4.8	50	100	6	
2HRBG 018 120 S04	0.9R X 1.8	2.1	12	50	4		2HRBG 040 550 S06	2R X 4	4.8	55	100	6	
2HRBG 018 160 S04	0.9R X 1.8	2.1	16	50	4		2HRBG 040 600 S06	2R X 4	4.8	60	100	6	
2HRBG 018 200 S04	0.9R X 1.8	2.1	20	50	4		2HRBG 050 150 S06	2.5R X 5	6	15	55	6	
2HRBG 020 040 S04	1R X 2	2.4	4	45	4		2HRBG 050 200 S06	2.5R X 5	6	20	60	6	
2HRBG 020 040 S06	1R X 2	2.4	4	45	6		2HRBG 050 250 S06	2.5R X 5	6	25	70	6	
2HRBG 020 060 S04	1R X 2	2.4	6	45	4		2HRBG 050 300 S06	2.5R X 5	6	30	75	6	
2HRBG 020 060 S06	1R X 2	2.4	6	45	6		2HRBG 050 400 S06	2.5R X 5	6	40	80	6	
2HRBG 020 080 S04	1R X 2	2.4	8	45	4		2HRBG 050 450 S06	2.5R X 5	6	45	90	6	
2HRBG 020 080 S06	1R X 2	2.4	8	45	6		2HRBG 050 500 S06	2.5R X 5	6	50	100	6	
2HRBG 020 100 S04	1R X 2	2.4	10	50	4		2HRBG 050 600 S06	2.5R X 5	6	60	100	6	
2HRBG 020 100 S06	1R X 2	2.4	10	50	6		2HRBG 060 150 S06	3R X 6	10	15	55	6	
2HRBG 020 120 S04	1R X 2	2.4	12	50	4		2HRBG 060 300 S06	3R X 6	10	30	110	6	
2HRBG 020 120 S06	1R X 2	2.4	12	50	6		2HRBG 080 250 060	4R X 8	12	25	60	8	
2HRBG 020 140 S04	1R X 2	2.4	14	50	4		2HRBG 080 300 100	4R X 8	12	30	100	8	
2HRBG 020 140 S06	1R X 2	2.4	14	50	6		2HRBG 100 300 070	5R X 10	16	30	70	10	
2HRBG 020 160 S04	1R X 2	2.4	16	50	4		2HRBG 100 350 100	5R X 10	16	35	100	10	
2HRBG 020 160 S06	1R X 2	2.4	16	55	6		2HRBG 120 300 075	6R X 12	18	30	75	12	
2HRBG 020 180 S04	1R X 2	2.4	18	50	4		2HRBG 120 400 110	6R X 12	18	40	110	12	
2HRBG 020 180 S06	1R X 2	2.4	18	60	6								
2HRBG 020 200 S04	1R X 2	2.4	20	50	4								
2HRBG 020 200 S06	1R X 2	2.4	20	60	6								
2HRBG 020 220 S04	1R X 2	2.4	22	60	4								
2HRBG 020 220 S06	1R X 2	2.4	22	65	6								

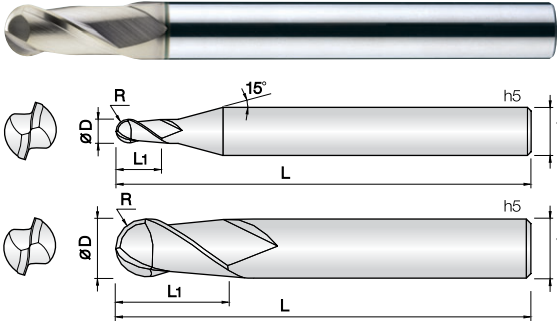

- 중저경도강(HRc52이하), 프리하든강 계열, 탄소강, 금형강 등 다양한 피삭재 가공
- JCRO 코팅 처리하여 넓은 영역의 피삭재 가공에 적합합니다.
- 고정밀 공차 적용으로 초정밀 가공에 적합합니다.
- 항절력이 높은 미립자 초경합금(0.5 μ m)을 채택, 엔드밀의 파손을 최소화 하였습니다.
- **Endmills for various work materials(~HRc52), pre-hardened steel, carbon steel, mold steel.**
- Optimum for various work materials by JCRO coating.
- High precise edge tolerance.
- Minimize fracturing by high TRS fine(0.5 μ m) WC grade.



D Size	D Tolerance
Ø0.2 ~ 5	+0 ~ -0.01mm
Ø6 ~ 12	-0.005 ~ -0.015mm
Ø16	-0.01 ~ -0.02mm

단위 : mm

Order Number	날경 Diameter R x D	날장 Length of cut L1	전장 Overall Length L	샙크 Shank Dia d	비고	Order Number	날경 Diameter R x D	날장 Length of cut L1	전장 Overall Length L	샙크 Shank Dia d	비고
2HCBG 001 002 S04	0.05R X 0.1	0.2	40	4		2HCBG 080 140 090	4R X 8	14	90	8	
2HCBG 0015 003 S04	0.075R X 0.15	0.3	40	4		2HCBG 080 140 110	4R X 8	14	110	8	
2HCBG 002 004 S04	0.1R X 0.2	0.4	40	4		2HCBG 080 140 150	4R X 8	14	150	8	
2HCBG 003 006 S04	0.15R X 0.3	0.6	40	4		2HCBG 090 160 S10	4.5R X 9	16	100	10	
2HCBG 004 008 S04	0.2R X 0.4	0.8	40	4		2HCBG 100 150 070	5R X 10	15	70	10	
2HCBG 005 010 S04	0.25R X 0.5	1	45	4		2HCBG 100 180 100	5R X 10	18	100	10	
2HCBG 006 012 S04	0.3R X 0.6	1.2	45	4		2HCBG 100 180 120	5R X 10	18	120	10	
2HCBG 007 015 S04	0.35R X 0.7	1.5	45	4		2HCBG 100 180 150	5R X 10	18	150	10	
2HCBG 008 020 S04	0.4R X 0.8	2	45	4		2HCBG 100 180 180	5R X 10	18	180	10	
2HCBG 009 020 S04	0.45R X 0.9	2	45	4		2HCBG 110 200 S12	5.5R X 11	20	110	12	
2HCBG 010 025 S04	0.5R X 1	2.5	50	4		2HCBG 120 180 070	6R X 12	18	70	12	
2HCBG 010 025 S06	0.5R X 1	2.5	50	6		2HCBG 120 220 110	6R X 12	22	110	12	
2HCBG 010 025 070	0.5R X 1	2.5	70	6		2HCBG 120 220 130	6R X 12	22	130	12	
2HCBG 010 025 100	0.5R X 1	2.5	100	6		2HCBG 120 220 150	6R X 12	22	150	12	
2HCBG 012 030 S04	0.6R X 1.2	3	50	4		2HCBG 120 220 200	6R X 12	22	200	12	
2HCBG 015 040 S04	0.75R X 1.5	4	50	4		2HCBG 130 240 S14	6.5R X 13	24	110	14	
2HCBG 015 040 S06	0.75R X 1.5	4	50	6		2HCBG 140 240 S14	7R X 14	24	110	14	
2HCBG 015 040 070	0.75R X 1.5	4	70	6		2HCBG 160 300 130	8R X 16	30	130	16	
2HCBG 015 040 100	0.75R X 1.5	4	100	6		2HCBG 160 300 160	8R X 16	30	160	16	
2HCBG 020 050 S04	1R X 2	5	50	4		2HCBG 160 300 200	8R X 16	30	200	16	
2HCBG 020 050 S06	1R X 2	5	50	6		2HCBG 200 380 160	10R X 20	38	160	20	
2HCBG 020 050 075	1R X 2	5	75	6		2HCBG 200 380 200	10R X 20	38	200	20	
2HCBG 020 050 100	1R X 2	5	100	6							
2HCBG 025 060 S04	1.25R X 2.5	6	50	4							
2HCBG 025 060 S06	1.25R X 2.5	6	60	6							
2HCBG 025 060 075	1.25R X 2.5	6	75	6							
2HCBG 025 060 100	1.25R X 2.5	6	100	6							
2HCBG 030 080 S03	1.5R X 3	8	60	3							
2HCBG 030 080 S04	1.5R X 3	8	50	4							
2HCBG 030 080 S06	1.5R X 3	8	60	6							
2HCBG 030 080 080	1.5R X 3	8	80	6							
2HCBG 030 080 100	1.5R X 3	8	100	6							
2HCBG 035 080 S06	1.75R X 3.5	8	60	6							
2HCBG 040 080 060	2R X 4	8	60	4							
2HCBG 040 080 080	2R X 4	8	80	4							
2HCBG 040 080 S06	2R X 4	8	70	6							
2HCBG 040 080 090	2R X 4	8	90	6							
2HCBG 040 080 120	2R X 4	8	120	6							
2HCBG 045 080 S06	2.25R X 4.5	8	70	6							
2HCBG 050 080 S05	2.5R X 5	8	80	5							
2HCBG 050 100 S06	2.5R X 5	10	75	6							
2HCBG 055 100 S06	2.75R X 5.5	10	75	6							
2HCBG 060 100 060	3R X 6	10	60	6							
2HCBG 060 120 080	3R X 6	12	80	6							
2HCBG 060 120 100	3R X 6	12	100	6							
2HCBG 060 120 120	3R X 6	12	120	6							
2HCBG 070 140 S08	3.5R X 7	14	80	8							
2HCBG 080 120 060	4R X 8	12	60	8							

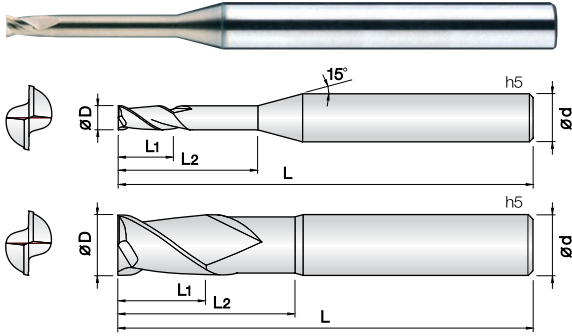

- 중저경도강(HRC52이하), 프리하든강 계열, 탄소강, 금형강 등 다양한 피삭재 가공
- JCRO 코팅 처리하여 넓은 영역의 피삭재 가공에 적합합니다.
- 고정밀 공차 적용으로 초정밀 가공에 적합합니다.
- 항절력이 높은 미립자 초경합금(0.5 μ m)을 채택, 엔드밀의 파손을 최소화 하였습니다.
- Endmills for various work materials(~HRC52), pre-hardened steel, carbon steel, mold steel.
- Optimum for various work materials by JCRO coating.
- High precise edge tolerance.
- Minimize fracturing by high TRS fine(0.5 μ m) WC grade.



D Size	D Tolerance
ø0.1	+0 ~ -0.05mm
ø0.2 ~ 5	+0 ~ -0.01mm
ø6 ~ 12	-0.01 ~ -0.025mm

단위 : mm

Order Number	날경 Diameter D	날장 Length of cut L1	유효장 Effective Length L2	전장 Overall Length L	샤프크 Shank Dia d	비고	Order Number	날경 Diameter D	날장 Length of cut L1	유효장 Effective Length L2	전장 Overall Length L	샤프크 Shank Dia d	비고
2HREG 001 003 S04	0.1	0.3	-	40	4		2HREG 008 080 S04	0.8	0.9	8	45	4	
2HREG 001 005 S04	0.1	0.5	-	40	4		2HREG 008 100 S04	0.8	0.9	10	45	4	
2HREG 002 005 S04	0.2	0.3	0.5	40	4		2HREG 008 120 S04	0.8	0.9	12	45	4	
2HREG 002 010 S04	0.2	0.2	1	40	4		2HREG 008 140 S04	0.8	0.9	14	45	4	
2HREG 002 015 S04	0.2	0.2	1.5	40	4		2HREG 009 060 S04	0.9	1	6	45	4	
2HREG 002 020 S04	0.2	0.2	2	40	4		2HREG 009 080 S04	0.9	1	8	45	4	
2HREG 003 010 S04	0.3	0.3	1	40	4		2HREG 009 100 S04	0.9	1	10	45	4	
2HREG 003 015 S04	0.3	0.3	1.5	40	4		2HREG 010 020 S04	1	1.2	2	45	4	
2HREG 003 020 S04	0.3	0.3	2	40	4		2HREG 010 030 S04	1	1.2	3	45	4	
2HREG 003 030 S04	0.3	0.3	3	40	4		2HREG 010 040 S04	1	1.2	4	45	4	
2HREG 003 040 S04	0.3	0.3	4	40	4		2HREG 010 050 S04	1	1.2	5	45	4	
2HREG 003 050 S04	0.3	0.3	5	40	4		2HREG 010 060 S04	1	1.2	6	45	4	
2HREG 004 010 S04	0.4	0.5	1	40	4		2HREG 010 080 S04	1	1.2	8	45	4	
2HREG 004 020 S04	0.4	0.5	2	40	4		2HREG 010 100 S04	1	1.2	10	50	4	
2HREG 004 030 S04	0.4	0.5	3	40	4		2HREG 010 120 S04	1	1.2	12	50	4	
2HREG 004 040 S04	0.4	0.5	4	40	4		2HREG 010 140 S04	1	1.2	14	50	4	
2HREG 004 050 S04	0.4	0.5	5	40	4		2HREG 010 160 S04	1	1.2	16	50	4	
2HREG 004 060 S04	0.4	0.5	6	40	4		2HREG 010 180 S04	1	1.2	18	50	4	
2HREG 004 080 S04	0.4	0.5	8	40	4		2HREG 010 200 S04	1	1.2	20	50	4	
2HREG 004 100 S04	0.4	0.5	10	40	4		2HREG 010 250 S04	1	1.2	25	60	4	
2HREG 005 020 S04	0.5	0.6	2	45	4		2HREG 010 300 S04	1	1.2	30	70	4	
2HREG 005 030 S04	0.5	0.6	3	45	4		2HREG 012 040 S04	1.2	1.4	4	45	4	
2HREG 005 040 S04	0.5	0.6	4	45	4		2HREG 012 060 S04	1.2	1.4	6	45	4	
2HREG 005 050 S04	0.5	0.6	5	45	4		2HREG 012 080 S04	1.2	1.4	8	45	4	
2HREG 005 060 S04	0.5	0.6	6	45	4		2HREG 012 100 S04	1.2	1.4	10	50	4	
2HREG 005 080 S04	0.5	0.6	8	45	4		2HREG 012 120 S04	1.2	1.4	12	50	4	
2HREG 005 100 S04	0.5	0.6	10	45	4		2HREG 012 160 S04	1.2	1.4	16	50	4	
2HREG 005 120 S04	0.5	0.6	12	45	4		2HREG 012 200 S04	1.2	1.4	20	50	4	
2HREG 005 140 S04	0.5	0.6	14	45	4		2HREG 012 250 S04	1.2	1.4	25	60	4	
2HREG 006 020 S04	0.6	0.7	2	45	4		2HREG 012 300 S04	1.2	1.4	30	70	4	
2HREG 006 030 S04	0.6	0.7	3	45	4		2HREG 014 060 S04	1.4	1.6	6	45	4	
2HREG 006 040 S04	0.6	0.7	4	45	4		2HREG 014 080 S04	1.4	1.6	8	45	4	
2HREG 006 050 S04	0.6	0.7	5	45	4		2HREG 014 100 S04	1.4	1.6	10	50	4	
2HREG 006 060 S04	0.6	0.7	6	45	4		2HREG 014 140 S04	1.4	1.6	14	50	4	
2HREG 006 080 S04	0.6	0.7	8	45	4		2HREG 014 160 S04	1.4	1.6	16	50	4	
2HREG 006 100 S04	0.6	0.7	10	45	4		2HREG 014 200 S04	1.4	1.6	20	50	4	
2HREG 006 120 S04	0.6	0.7	12	45	4		2HREG 015 040 S04	1.5	1.8	4	45	4	
2HREG 006 140 S04	0.6	0.7	14	45	4		2HREG 015 060 S04	1.5	1.8	6	45	4	
2HREG 006 160 S04	0.6	0.7	16	45	4		2HREG 015 080 S04	1.5	1.8	8	45	4	
2HREG 007 020 S04	0.7	0.8	2	45	4		2HREG 015 100 S04	1.5	1.8	10	50	4	
2HREG 007 040 S04	0.7	0.8	4	45	4		2HREG 015 120 S04	1.5	1.8	12	50	4	
2HREG 007 060 S04	0.7	0.8	6	45	4		2HREG 015 140 S04	1.5	1.8	14	50	4	
2HREG 007 080 S04	0.7	0.8	8	45	4		2HREG 015 160 S04	1.5	1.8	16	50	4	
2HREG 007 100 S04	0.7	0.8	10	45	4		2HREG 015 180 S04	1.5	1.8	18	50	4	
2HREG 007 120 S04	0.7	0.8	12	45	4		2HREG 015 200 S04	1.5	1.8	20	50	4	
2HREG 008 020 S04	0.8	0.9	2	45	4		2HREG 015 250 S04	1.5	1.8	25	60	4	
2HREG 008 040 S04	0.8	0.9	4	45	4		2HREG 015 300 S04	1.5	1.8	30	70	4	
2HREG 008 060 S04	0.8	0.9	6	45	4		2HREG 016 100 S04	1.6	1.9	10	50	4	

단위 : mm

Order Number	날경 Diameter D	날장 Length of cut L1	유효장 Effective Length L2	전장 Overall Length L	샙크 Shank Dia d	비고	Order Number	날경 Diameter D	날장 Length of cut L1	유효장 Effective Length L2	전장 Overall Length L	샙크 Shank Dia d	비고
2HREG 016 140 S04	1.6	1.9	14	50	4		2HREG 040 200 S06	4	4.8	20	60	6	
2HREG 016 180 S04	1.6	1.9	18	50	4		2HREG 040 250 S06	4	4.8	25	65	6	
2HREG 018 100 S04	1.8	2.1	10	50	4		2HREG 040 300 S06	4	4.8	30	70	6	
2HREG 018 140 S04	1.8	2.1	14	50	4		2HREG 040 350 S06	4	4.8	35	75	6	
2HREG 018 180 S04	1.8	2.1	18	50	4		2HREG 040 400 S06	4	4.8	40	80	6	
2HREG 020 040 S04	2	2.4	4	45	4		2HREG 040 450 S06	4	4.8	45	90	6	
2HREG 020 060 S04	2	2.4	6	45	4		2HREG 040 500 S06	4	4.8	50	100	6	
2HREG 020 080 S04	2	2.4	8	45	4		2HREG 040 550 S06	4	4.8	55	100	6	
2HREG 020 100 S04	2	2.4	10	50	4		2HREG 040 600 S06	4	4.8	60	100	6	
2HREG 020 120 S04	2	2.4	12	50	4		2HREG 050 150 S06	5	6	15	55	6	
2HREG 020 140 S04	2	2.4	14	50	4		2HREG 050 200 S06	5	6	20	60	6	
2HREG 020 160 S04	2	2.4	16	50	4		2HREG 050 250 S06	5	6	25	70	6	
2HREG 020 180 S04	2	2.4	18	50	4		2HREG 050 300 S06	5	6	30	75	6	
2HREG 020 200 S04	2	2.4	20	50	4		2HREG 050 350 S06	5	6	35	75	6	
2HREG 020 220 S04	2	2.4	22	60	4		2HREG 050 400 S06	5	6	40	80	6	
2HREG 020 250 S04	2	2.4	25	60	4		2HREG 050 500 S06	5	6	50	100	6	
2HREG 020 300 S04	2	2.4	30	70	4		2HREG 050 600 S06	5	6	60	100	6	
2HREG 020 350 S04	2	2.4	35	70	4		2HREG 060 200 S06	6	10	20	60	6	
2HREG 020 400 S04	2	2.4	40	80	4		2HREG 060 300 S06	6	10	30	75	6	
2HREG 020 450 S04	2	2.4	45	80	4		2HREG 060 400 S06	6	10	40	80	6	
2HREG 020 500 S04	2	2.4	50	90	4		2HREG 060 500 S06	6	10	50	90	6	
2HREG 025 080 S04	2.5	3	8	45	4		2HREG 060 600 S06	6	10	60	110	6	
2HREG 025 100 S04	2.5	3	10	50	4		2HREG 080 200 S08	8	12	20	65	8	
2HREG 025 120 S04	2.5	3	12	50	4		2HREG 080 300 S08	8	12	30	80	8	
2HREG 025 160 S04	2.5	3	16	50	4		2HREG 080 400 S08	8	12	40	100	8	
2HREG 025 200 S04	2.5	3	20	50	4		2HREG 100 250 S10	10	15	25	70	10	
2HREG 025 250 S04	2.5	3	25	60	4		2HREG 100 350 S10	10	15	35	80	10	
2HREG 025 300 S04	2.5	3	30	70	4		2HREG 100 450 S10	10	15	45	100	10	
2HREG 025 350 S04	2.5	3	35	70	4		2HREG 120 300 S12	12	18	30	80	12	
2HREG 025 400 S04	2.5	3	40	80	4		2HREG 120 400 S12	12	18	40	100	12	
2HREG 025 500 S04	2.5	3	50	90	4		2HREG 120 500 S12	12	18	50	120	12	
2HREG 030 060 S06	3	3.6	6	45	6								
2HREG 030 080 S06	3	3.6	8	45	6								
2HREG 030 100 S06	3	3.6	10	50	6								
2HREG 030 120 S06	3	3.6	12	50	6								
2HREG 030 160 S06	3	3.6	16	55	6								
2HREG 030 200 S06	3	3.6	20	60	6								
2HREG 030 250 S06	3	3.6	25	65	6								
2HREG 030 300 S06	3	3.6	30	70	6								
2HREG 030 350 S06	3	3.6	35	75	6								
2HREG 030 400 S06	3	3.6	40	80	6								
2HREG 030 450 S06	3	3.6	45	90	6								
2HREG 030 500 S06	3	3.6	50	100	6								
2HREG 030 600 S06	3	3.6	60	100	6								
2HREG 040 080 S06	4	4.8	8	45	6								
2HREG 040 100 S06	4	4.8	10	50	6								
2HREG 040 120 S06	4	4.8	12	50	6								
2HREG 040 160 S06	4	4.8	16	55	6								

4날 범용 리브 엔드밀

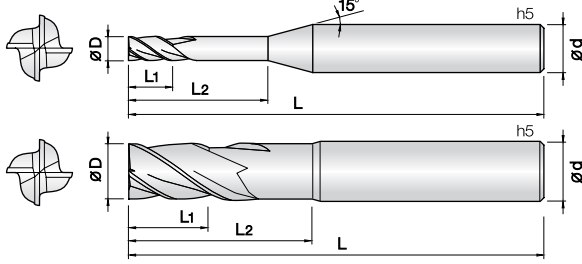

• 중저경도강(HRc52이하), 프리하드강 계열, 탄소강, 금형강 등 다양한 피삭재 가공

- JCRO 코팅 처리하여 넓은 영역의 피삭재 가공에 적합합니다.
- 고정밀 공차 적용으로 초정밀 가공에 적합합니다.
- 항절력이 높은 미립자 초경합금(0.5 μ m)을 채택, 엔드밀의 파손을 최소화 하였습니다.

• Endmills for various work materials(~HRc52), pre-hardened steel, carbon steel, mold steel.

- Optimum for various work materials by JCRO coating.
- High precise edge tolerance.
- Minimize fracturing by high TRS fine(0.5 μ m) WC grade.



D Size	D Tolerance
$\phi 0.8 \sim 5$	+0 ~ -0.01mm
$\phi 6 \sim 12$	-0.01 ~ -0.025mm

단위 : mm

Order Number	날경 Diameter D	날장 Length of cut L1	유효장 Effective Length L2	전장 Overall Length L	샙크 Shank Dia d	비고	Order Number	날경 Diameter D	날장 Length of cut L1	유효장 Effective Length L2	전장 Overall Length L	샙크 Shank Dia d	비고
4HREG 008 020 S04	0.8	0.9	2	45	4		4HREG 030 160 S06	3	3.6	16	55	6	
4HREG 008 040 S04	0.8	0.9	4	45	4		4HREG 030 200 S06	3	3.6	20	60	6	
4HREG 008 060 S04	0.8	0.9	6	45	4		4HREG 030 250 S06	3	3.6	25	65	6	
4HREG 008 080 S04	0.8	0.9	8	45	4		4HREG 030 300 S06	3	3.6	30	70	6	
4HREG 008 100 S04	0.8	0.9	10	45	4		4HREG 030 350 S06	3	3.6	35	75	6	
4HREG 008 120 S04	0.8	0.9	12	45	4		4HREG 030 400 S06	3	3.6	40	80	6	
4HREG 008 160 S04	0.8	0.9	16	45	4		4HREG 040 100 S06	4	4.8	10	50	6	
4HREG 009 020 S04	0.9	1	2	45	4		4HREG 040 120 S06	4	4.8	12	50	6	
4HREG 009 060 S04	0.9	1	6	45	4		4HREG 040 160 S06	4	4.8	16	55	6	
4HREG 009 080 S04	0.9	1	8	45	4		4HREG 040 200 S06	4	4.8	20	60	6	
4HREG 009 100 S04	0.9	1	10	45	4		4HREG 040 250 S06	4	4.8	25	65	6	
4HREG 010 030 S04	1	1.2	3	45	4		4HREG 040 300 S06	4	4.8	30	70	6	
4HREG 010 040 S04	1	1.2	4	45	4		4HREG 040 400 S06	4	4.8	40	80	6	
4HREG 010 060 S04	1	1.2	6	45	4		4HREG 040 450 S06	4	4.8	45	90	6	
4HREG 010 080 S04	1	1.2	8	45	4		4HREG 040 500 S06	4	4.8	50	100	6	
4HREG 010 100 S04	1	1.2	10	50	4		4HREG 050 150 S06	5	6	15	55	6	
4HREG 010 120 S04	1	1.2	12	50	4		4HREG 050 200 S06	5	6	20	60	6	
4HREG 010 160 S04	1	1.2	16	50	4		4HREG 050 250 S06	5	6	25	65	6	
4HREG 010 200 S04	1	1.2	20	50	4		4HREG 050 300 S06	5	6	30	70	6	
4HREG 010 250 S04	1	1.2	25	60	4		4HREG 050 400 S06	5	6	40	80	6	
4HREG 012 060 S04	1.2	1.4	6	45	4		4HREG 050 500 S06	5	6	50	100	6	
4HREG 012 080 S04	1.2	1.4	8	45	4		4HREG 060 200 S06	6	10	20	60	6	
4HREG 012 100 S04	1.2	1.4	10	50	4		4HREG 060 300 S06	6	10	30	75	6	
4HREG 012 120 S04	1.2	1.4	12	50	4		4HREG 060 400 S06	6	10	40	80	6	
4HREG 012 160 S04	1.2	1.4	16	50	4		4HREG 060 500 S06	6	10	50	90	6	
4HREG 015 060 S04	1.5	1.8	6	45	4		4HREG 080 200 S08	8	12	20	65	8	
4HREG 015 080 S04	1.5	1.8	8	45	4		4HREG 080 300 S08	8	12	30	80	8	
4HREG 015 100 S04	1.5	1.8	10	50	4		4HREG 080 400 S08	8	12	40	100	8	
4HREG 015 120 S04	1.5	1.8	12	50	4		4HREG 100 250 S10	10	15	25	70	10	
4HREG 015 160 S04	1.5	1.8	16	50	4		4HREG 100 350 S10	10	15	35	90	10	
4HREG 015 200 S04	1.5	1.8	20	50	4		4HREG 100 450 S10	10	15	45	110	10	
4HREG 015 250 S04	1.5	1.8	25	60	4		4HREG 120 300 S12	12	18	30	80	12	
4HREG 020 060 S04	2	2.4	6	45	4		4HREG 120 400 S12	12	18	40	100	12	
4HREG 020 080 S04	2	2.4	8	45	4		4HREG 120 500 S12	12	18	50	120	12	
4HREG 020 100 S04	2	2.4	10	50	4								
4HREG 020 120 S04	2	2.4	12	50	4								
4HREG 020 160 S04	2	2.4	16	50	4								
4HREG 020 200 S04	2	2.4	20	50	4								
4HREG 020 250 S04	2	2.4	25	60	4								
4HREG 020 300 S04	2	2.4	30	70	4								
4HREG 025 100 S04	2.5	3	10	50	4								
4HREG 025 120 S04	2.5	3	12	50	4								
4HREG 025 160 S04	2.5	3	16	50	4								
4HREG 025 200 S04	2.5	3	20	50	4								
4HREG 025 250 S04	2.5	3	25	60	4								
4HREG 025 300 S04	2.5	3	30	70	4								
4HREG 030 100 S06	3	3.6	10	50	6								
4HREG 030 120 S06	3	3.6	12	50	6								

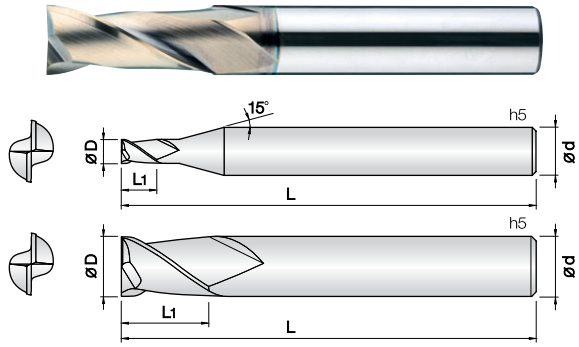

- 중저경도강(HRc52이하), 프리하든강 계열, 탄소강, 금형강 등 다양한 피삭재 가공
- JCRO 코팅 처리하여 넓은 영역의 피삭재 가공에 적합합니다.
- 고정밀 공차 적용으로 초정밀 가공에 적합합니다.
- 항절력이 높은 미립자 초경합금(0.5 μ m)을 채택, 엔드밀의 파손을 최소화 하였습니다.
- Endmills for various work materials(~HRc52), pre-hardened steel, carbon steel, mold steel.
- Optimum for various work materials by JCRO coating.
- High precise edge tolerance.
- Minimize fracturing by high TRS fine(0.5 μ m) WC grade.

2

WC
미립자

JCRO
Coating

D
+0 -0.005

D
+0 -0.01

D
-0.01 -0.025

D
-0.015 -0.03

35°
Helix Angle

Shield Edge

D Size	D Tolerance
ø0.1 ~ 0.15	+0 ~ -0.005mm
ø0.2 ~ 5.5	+0 ~ -0.01mm
ø6 ~ 12	-0.01 ~ -0.025mm
ø14 ~ 20	-0.015 ~ -0.03mm

Order Number	날경 Diameter D	날장 Length of cut L1	전장 Overall Length L	샙크 Shank Dia d	비고	Order Number	날경 Diameter D	날장 Length of cut L1	전장 Overall Length L	샙크 Shank Dia d	비고
2HCEG 001 002 S04	0.1	0.2	40	4		2HCEG 025 080 S06	2.5	8	45	6	
2HCEG 0015 003 S04	0.15	0.3	40	4		2HCEG 025 080 070	2.5	8	70	6	
2HCEG 002 004 S04	0.2	0.4	40	4		2HCEG 026 080 S04	2.6	8	45	4	
2HCEG 0025 005 S04	0.25	0.5	40	4		2HCEG 027 080 S04	2.7	8	45	4	
2HCEG 003 006 S04	0.3	0.6	40	4		2HCEG 028 080 S04	2.8	8	45	4	
2HCEG 0035 007 S04	0.35	0.7	40	4		2HCEG 029 080 S04	2.9	8	45	4	
2HCEG 004 008 S04	0.4	0.8	40	4		2HCEG 030 030 S04	3	3	40	4	
2HCEG 0045 009 S04	0.45	0.9	40	4		2HCEG 030 080 S04	3	8	45	4	
2HCEG 005 010 S04	0.5	1	40	4		2HCEG 030 080 S06	3	8	45	6	
2HCEG 0055 011 S04	0.55	1.1	40	4		2HCEG 030 080 070	3	8	70	6	
2HCEG 006 012 S04	0.6	1.2	40	4		2HCEG 035 100 S06	3.5	10	45	6	
2HCEG 0065 013 S04	0.65	1.3	40	4		2HCEG 040 040 S04	4	4	40	4	
2HCEG 007 014 S04	0.7	1.4	40	4		2HCEG 040 100 S04	4	10	45	4	
2HCEG 0075 015 S04	0.75	1.5	40	4		2HCEG 040 110 S06	4	11	45	6	
2HCEG 008 016 S04	0.8	1.6	40	4		2HCEG 040 110 070	4	11	70	6	
2HCEG 0085 017 S04	0.85	1.7	40	4		2HCEG 045 110 S06	4.5	11	45	6	
2HCEG 009 020 S04	0.9	2	40	4		2HCEG 050 130 S06	5	13	50	6	
2HCEG 0095 020 S04	0.95	2	40	4		2HCEG 050 130 080	5	13	80	6	
2HCEG 010 010 S04	1	1	40	4		2HCEG 055 130 S06	5.5	13	50	6	
2HCEG 010 025 S04	1	2.5	40	4		2HCEG 060 060 S06	6	6	45	6	
2HCEG 010 025 S06	1	2.5	40	6		2HCEG 060 130 S06	6	13	50	6	
2HCEG 010 025 060	1	2.5	60	6		2HCEG 060 130 080	6	13	80	6	
2HCEG 010 040 S06	1	4	50	6		2HCEG 060 150 S06	6	15	60	6	
2HCEG 011 027 S04	1.1	2.7	40	4		2HCEG 065 160 S08	6.5	16	60	8	
2HCEG 012 012 S04	1.2	1.2	40	4		2HCEG 070 160 S08	7	16	60	8	
2HCEG 012 030 S04	1.2	3	40	4		2HCEG 075 160 S08	7.5	16	60	8	
2HCEG 012 030 S06	1.2	3	40	6		2HCEG 080 080 S08	8	8	50	8	
2HCEG 012 030 060	1.2	3	60	6		2HCEG 080 190 S08	8	19	60	8	
2HCEG 012 060 S06	1.2	6	50	6		2HCEG 080 200 S08	8	20	70	8	
2HCEG 013 032 S04	1.3	3.2	40	4		2HCEG 085 190 S10	8.5	19	70	10	
2HCEG 014 035 S04	1.4	3.5	40	4		2HCEG 090 190 S10	9	19	70	10	
2HCEG 015 015 S04	1.5	1.5	40	4		2HCEG 095 190 S10	9.5	19	70	10	
2HCEG 015 040 S04	1.5	4	40	4		2HCEG 100 100 S10	10	10	60	10	
2HCEG 015 040 S06	1.5	4	40	6		2HCEG 100 220 S10	10	22	70	10	
2HCEG 015 040 060	1.5	4	60	6		2HCEG 100 250 S10	10	25	75	10	
2HCEG 016 040 S04	1.6	4	40	4		2HCEG 105 220 S12	10.5	22	75	12	
2HCEG 017 042 S04	1.7	4.2	40	4		2HCEG 110 220 S12	11	22	75	12	
2HCEG 018 045 S04	1.8	4.5	40	4		2HCEG 115 220 S12	11.5	22	75	12	
2HCEG 019 050 S04	1.9	5	40	4		2HCEG 120 120 S12	12	12	65	12	
2HCEG 020 020 S04	2	2	40	4		2HCEG 120 260 S12	12	26	75	12	
2HCEG 020 060 S04	2	6	40	4		2HCEG 120 300 S12	12	30	80	12	
2HCEG 020 060 S06	2	6	40	6		2HCEG 140 260 S14	14	26	80	14	
2HCEG 020 060 060	2	6	60	6		2HCEG 140 260 S16	14	26	85	16	
2HCEG 021 060 S04	2.1	6	40	4		2HCEG 160 350 S16	16	35	100	16	
2HCEG 022 060 S04	2.2	6	40	4		2HCEG 160 400 S16	16	40	100	16	
2HCEG 023 060 S04	2.3	6	40	4		2HCEG 180 350 S18	18	35	100	18	
2HCEG 024 080 S04	2.4	8	45	4		2HCEG 200 400 S20	20	40	100	20	
2HCEG 025 080 S04	2.5	8	45	4		2HCEG 200 500 S20	20	50	110	20	

단위 : mm

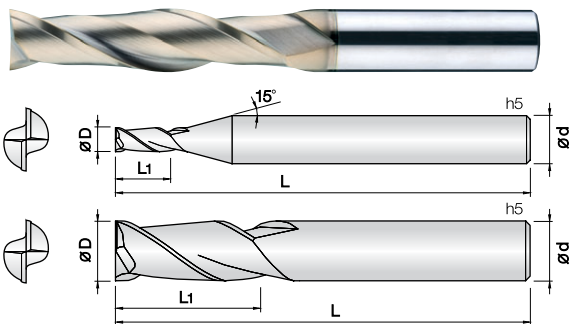

- 중저경도강(HRC52이하), 프리하드강 계열, 탄소강, 금형강 등 가공
- JCRO 코팅 처리하여 넓은 영역의 피삭재 가공에 적합합니다.
- 균일한 런아웃 공차관리로 공구의 성능을 향상시켰습니다.
- 다양한 날길이와 전장을 채택, 다양한 작업에 효율성을 극대화 하였습니다.
- 코너부 강성을 보강하여 날부치평을 최소화 하였습니다.
- **Endmills for various work materials(~HRC52), pre-hardened steel, carbon steel, mold steel.**
- Optimum for various work materials by JCRO coating.
- Improve tool performance by even run-out and tolerance control.
- Various flute and overall length design for covering wide range applications as well as high efficiency machining.
- Minimize edge chipping by improving corner strength.



D Size	D Tolerance
Ø1 ~ 5	+0 ~ -0.01mm
Ø6 ~ 12	-0.01 ~ -0.025mm
Ø14 ~ 25	-0.015 ~ -0.03mm

단위 : mm

Order Number	날경 Diameter D	날장 Length of cut L1	전장 Overall Length L	샙크 Shank Dia d	비고	Order Number	날경 Diameter D	날장 Length of cut L1	전장 Overall Length L	샙크 Shank Dia d	비고
2LEMG 010 030 S06	1	3	60	6		2LEMG 160 400 160	16	40	160	16	
2LEMG 010 050 S06	1	5	60	6		2LEMG 160 550 S16	16	55	120	16	
2LEMG 010 070 S06	1	7	60	6		2LEMG 160 700 S16	16	70	130	16	
2LEMG 010 100 S06	1	10	60	6		2LEMG 160 800 S16	16	80	160	16	
2LEMG 010 150 S06	1	15	60	6		2LEMG 200 500 160	20	50	160	20	
2LEMG 015 060 S06	1.5	6	60	6		2LEMG 200 600 S20	20	60	130	20	
2LEMG 015 075 S06	1.5	7.5	60	6		2LEMG 200 1000 S20	20	100	200	20	
2LEMG 015 100 S06	1.5	10	60	6		2LEMG 250 750 S25	25	75	160	25	
2LEMG 015 150 S06	1.5	15	60	6							
2LEMG 015 200 S06	1.5	20	60	6							
2LEMG 020 060 S06	2	6	60	6							
2LEMG 020 100 S06	2	10	60	6							
2LEMG 020 150 S06	2	15	60	6							
2LEMG 020 200 S06	2	20	60	6							
2LEMG 030 120 S06	3	12	70	6							
2LEMG 030 150 S06	3	15	70	6							
2LEMG 030 200 S06	3	20	70	6							
2LEMG 030 250 S06	3	25	70	6							
2LEMG 030 300 S06	3	30	70	6							
2LEMG 040 150 S06	4	15	70	6							
2LEMG 040 200 S06	4	20	70	6							
2LEMG 040 300 S06	4	30	75	6							
2LEMG 050 200 S06	5	20	70	6							
2LEMG 050 250 S06	5	25	75	6							
2LEMG 050 300 S06	5	30	80	6							
2LEMG 060 200 S06	6	20	75	6							
2LEMG 060 200 100	6	20	100	6							
2LEMG 060 250 S06	6	25	75	6							
2LEMG 060 300 S06	6	30	80	6							
2LEMG 080 250 S08	8	25	75	8							
2LEMG 080 250 100	8	25	100	8							
2LEMG 080 300 S08	8	30	80	8							
2LEMG 080 350 S08	8	35	80	8							
2LEMG 080 400 S08	8	40	90	8							
2LEMG 080 500 S08	8	50	100	8							
2LEMG 100 300 S10	10	30	80	10							
2LEMG 100 300 110	10	30	110	10							
2LEMG 100 350 S10	10	35	90	10							
2LEMG 100 400 S10	10	40	90	10							
2LEMG 100 500 S10	10	50	100	10							
2LEMG 100 600 S10	10	60	110	10							
2LEMG 120 300 S12	12	30	90	12							
2LEMG 120 350 110	12	35	110	12							
2LEMG 120 400 S12	12	40	100	12							
2LEMG 120 500 S12	12	50	100	12							
2LEMG 120 600 S12	12	60	110	12							
2LEMG 120 700 S12	12	70	130	12							
2LEMG 140 500 S14	14	50	110	14							

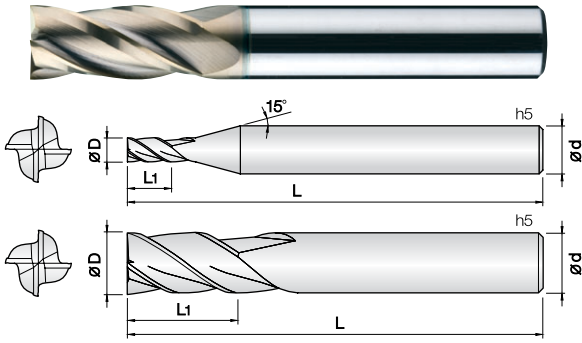

- 중저경도강(HRc52이하), 프리하든강 계열, 탄소강, 금형강 등 다양한 피삭재 가공
- JCRO 코팅 처리하여 넓은 영역의 피삭재 가공에 적합합니다.
- 고정밀 공차 적용으로 초정밀 가공에 적합합니다.
- 항절력이 높은 미립자 초경합금(0.5 μ m)을 채택, 엔드밀의 파손을 최소화 하였습니다.
- **Endmills for various work materials(~HRc52), pre-hardened steel, carbon steel, mold steel.**
- Optimum for various work materials by JCRO coating.
- High precise edge tolerance.
- Minimize fracturing by high TRS fine(0.5 μ m) WC grade.



D Size	D Tolerance
ø0.8 ~ 5.5	+0 ~ -0.01mm
ø6 ~ 12	-0.01 ~ -0.025mm
ø14 ~ 20	-0.015 ~ -0.03mm

단위 : mm

Order Number	날경 Diameter D	날장 Length of cut L1	전장 Overall Length L	샙크 Shank Dia d	비고	Order Number	날경 Diameter D	날장 Length of cut L1	전장 Overall Length L	샙크 Shank Dia d	비고
4HCEG 008 020 S04	0.8	2	40	4		4HCEG 070 160 S08	7	16	60	8	
4HCEG 010 010 S04	1	1	40	4		4HCEG 075 160 S08	7.5	16	60	8	
4HCEG 010 025 S04	1	2.5	40	4		4HCEG 080 080 S08	8	8	50	8	
4HCEG 010 025 S06	1	2.5	40	6		4HCEG 080 190 S08	8	19	60	8	
4HCEG 010 025 060	1	2.5	60	6		4HCEG 080 200 S08	8	20	70	8	
4HCEG 010 025 080	1	2.5	80	6		4HCEG 085 190 S10	8.5	19	70	10	
4HCEG 010 040 S06	1	4	50	6		4HCEG 090 190 S10	9	19	70	10	
4HCEG 012 012 S04	1.2	1.2	40	4		4HCEG 095 190 S10	9.5	19	70	10	
4HCEG 012 030 S04	1.2	3	40	4		4HCEG 100 100 S10	10	10	60	10	
4HCEG 012 030 S06	1.2	3	40	6		4HCEG 100 220 S10	10	22	70	10	
4HCEG 012 030 060	1.2	3	60	6		4HCEG 100 250 S10	10	25	75	10	
4HCEG 012 060 S06	1.5	6	50	6		4HCEG 105 220 S12	10.5	22	75	12	
4HCEG 015 015 S04	1.5	1.5	40	4		4HCEG 110 220 S12	11	22	75	12	
4HCEG 015 040 S04	1.5	4	40	4		4HCEG 115 220 S12	11.5	22	75	12	
4HCEG 015 040 S06	1.5	4	40	6		4HCEG 120 120 S12	12	12	65	12	
4HCEG 015 040 060	1.5	4	60	6		4HCEG 120 260 S12	12	26	75	12	
4HCEG 015 040 080	1.5	4	80	6		4HCEG 120 300 S12	12	30	80	12	
4HCEG 020 020 S04	2	2	40	4		4HCEG 140 260 S14	14	26	80	14	
4HCEG 020 060 S04	2	6	40	4		4HCEG 140 260 S16	14	26	85	16	
4HCEG 020 060 S06	2	6	40	6		4HCEG 160 350 S16	16	35	100	16	
4HCEG 020 060 060	2	6	60	6		4HCEG 160 400 S16	16	40	100	16	
4HCEG 020 060 100	2	6	100	6		4HCEG 180 350 S18	18	35	100	18	
4HCEG 025 080 S04	2.5	8	45	4		4HCEG 200 400 S20	20	40	100	20	
4HCEG 025 080 S06	2.5	8	45	6		4HCEG 200 450 S20	20	45	100	20	
4HCEG 025 080 070	2.5	8	70	6							
4HCEG 025 080 100	2.5	8	100	6							
4HCEG 030 080 S03	3	8	45	3							
4HCEG 030 080 S04	3	8	45	4							
4HCEG 030 080 S06	3	8	45	6							
4HCEG 030 080 070	3	8	70	6							
4HCEG 030 080 100	3	8	100	6							
4HCEG 035 100 S06	3.5	10	45	6							
4HCEG 040 040 S04	4	4	40	4							
4HCEG 040 110 S04	4	11	45	4							
4HCEG 040 110 S06	4	11	45	6							
4HCEG 040 110 070	4	11	70	6							
4HCEG 040 110 100	4	11	100	6							
4HCEG 045 110 S06	4.5	11	45	6							
4HCEG 050 130 S06	5	13	50	6							
4HCEG 050 130 080	5	13	80	6							
4HCEG 050 130 100	5	13	100	6							
4HCEG 055 130 S06	5.5	13	50	6							
4HCEG 060 060 S06	6	6	45	6							
4HCEG 060 130 S06	6	13	50	6							
4HCEG 060 130 080	6	13	80	6							
4HCEG 060 130 100	6	13	100	6							
4HCEG 060 150 S06	6	15	60	6							
4HCEG 065 160 S08	6.5	16	60	8							

4날 범용 긴 길이 엔드밀

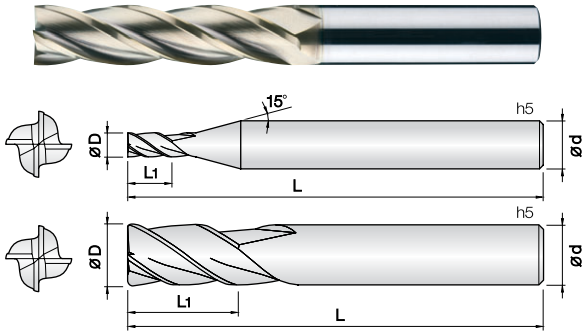

- 중저경도강(HRc52이하), 프리하든강 계열, 탄소강, 금형강 등 가공
- JCRO 코팅 처리하여 넓은 영역의 피삭재 가공에 적합합니다.
- 균일한 런아웃 공차관리로 공구의 성능을 향상시켰습니다.
- 다양한 날길이와 전장을 채택, 다양한 작업에 효율성을 극대화 하였습니다.
- 코너부 강성을 보강하여 날부치핑을 최소화 하였습니다.
- **Endmills for various work materials(~HRc52), pre-hardened steel, carbon steel, mold steel.**
- Optimum for various work materials by JCRO coating.
- Improve tool performance by even run-out and tolerance control.
- Various flute and overall length design for covering wide range applications as well as high efficiency machining.
- Minimize edge chipping by improving corner strength.

4

WC
미립자

JCRO
Coating

D
+0 -0.01

D
-0.01 -0.025

D
-0.015 -0.03

35°
Helix Angle

Shield Edge

D Size	D Tolerance
ø1 ~ 5	+0 ~ -0.01mm
ø6 ~ 12	-0.01 ~ -0.025mm
ø14 ~ 25	-0.015 ~ -0.03mm

단위 : mm

Order Number	날경 Diameter D	날장 Length of cut L1	전장 Overall Length L	생크 Shank Dia d	비고	Order Number	날경 Diameter D	날장 Length of cut L1	전장 Overall Length L	생크 Shank Dia d	비고
4LEMG 010 030 S06	1	3	60	6		4LEMG 200 500 160	20	50	160	20	
4LEMG 010 050 S06	1	5	60	6		4LEMG 200 600 S20	20	60	130	20	
4LEMG 015 060 S06	1.5	6	60	6		4LEMG 200 1000 S20	20	100	200	20	
4LEMG 015 080 S06	1.5	8	60	6		4LEMG 250 750 S25	25	75	160	25	
4LEMG 020 080 S06	2	8	60	6							
4LEMG 020 100 S06	2	10	60	6							
4LEMG 030 100 S06	3	10	70	6							
4LEMG 030 150 S06	3	15	70	6							
4LEMG 030 200 S06	3	20	70	6							
4LEMG 030 250 S06	3	25	70	6							
4LEMG 040 120 S06	4	12	70	6							
4LEMG 040 150 S04	4	15	70	4							
4LEMG 040 150 S06	4	15	70	6							
4LEMG 040 200 S04	4	20	70	4							
4LEMG 040 200 S06	4	20	70	6							
4LEMG 040 250 S06	4	25	70	6							
4LEMG 040 300 S06	4	30	75	6							
4LEMG 050 200 S06	5	20	70	6							
4LEMG 050 250 S06	5	25	75	6							
4LEMG 050 300 S06	5	30	80	6							
4LEMG 060 200 S06	6	20	75	6							
4LEMG 060 200 100	6	20	100	6							
4LEMG 060 250 S06	6	25	75	6							
4LEMG 060 300 S06	6	30	80	6							
4LEMG 060 350 S06	6	35	80	6							
4LEMG 080 250 S08	8	25	75	8							
4LEMG 080 250 100	8	25	100	8							
4LEMG 080 300 S08	8	30	80	8							
4LEMG 080 350 S08	8	35	90	8							
4LEMG 080 400 S08	8	40	90	8							
4LEMG 080 450 S08	8	45	100	8							
4LEMG 100 300 S10	10	30	80	10							
4LEMG 100 300 110	10	30	110	10							
4LEMG 100 350 S10	10	35	90	10							
4LEMG 100 400 S10	10	40	90	10							
4LEMG 100 500 S10	10	50	100	10							
4LEMG 100 600 S10	10	60	110	10							
4LEMG 120 300 S12	12	30	90	12							
4LEMG 120 350 110	12	35	110	12							
4LEMG 120 400 S12	12	40	100	12							
4LEMG 120 500 S12	12	50	100	12							
4LEMG 120 600 S12	12	60	110	12							
4LEMG 120 700 S12	12	70	130	12							
4LEMG 140 500 S14	14	50	110	14							
4LEMG 160 400 160	16	40	160	16							
4LEMG 160 550 S16	16	55	120	16							
4LEMG 160 700 S16	16	70	130	16							
New 4LEMG 180 800 160	18	80	160	18							

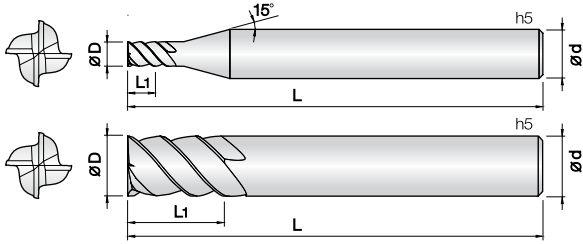

- 중저경도강(HRC52이하), 프리하든강 계열, 탄소강, 금형강 등 다양한 피삭재 가공
- JCRO 코팅 처리하여 넓은 영역의 피삭재 가공에 적합합니다.
- 고정밀 공차 적용으로 초정밀 가공에 적합합니다.
- 45° 헬릭스 형상으로 설계하여 고속, 고이송 가공에 적합합니다.
- 항절력이 높은 미립자 초경합금(0.5 μ m)을 채택, 엔드밀의 파손을 최소화 하였습니다.
- **Endmills for various work materials(~HRC52), pre-hardened steel, carbon steel, mold steel.**
- Optimum for various work materials by JCRO coating.
- High precise edge tolerance.
- 45° degree helix design for high speed, feed condition.
- Minimize fracturing by high TRS fine(0.5 μ m) WC grade.

4

WC
미립자

JCRO
Coating

D
+0 -0.01

D
-0.01 -0.025

D
-0.015 -0.03

45°
Helix Angle

Shield Edge

D Size	D Tolerance
Ø1 ~ 5	+0 ~ -0.01mm
Ø6 ~ 12	-0.01 ~ -0.025mm
Ø16 ~ 20	-0.015 ~ -0.03mm

단위 : mm

Order Number	날경 Diameter D	날장 Length of cut L1	전장 Overall Length L	샙크 Shank Dia d	비고										
4HEMG 010 025 S06	1	2.5	40	6											
4HEMG 010 035 S06	1	3.5	40	6											
4HEMG 015 040 S06	1.5	4	40	6											
4HEMG 015 060 S06	1.5	6	40	6											
4HEMG 020 050 S06	2	5	40	6											
4HEMG 020 080 S06	2	8	45	6											
4HEMG 030 080 S06	3	8	45	6											
4HEMG 030 120 S06	3	12	50	6											
4HEMG 040 110 S06	4	11	45	6											
4HEMG 040 160 S06	4	16	55	6											
4HEMG 050 130 S06	5	13	50	6											
4HEMG 050 180 S06	5	18	60	6											
4HEMG 060 130 S06	6	13	50	6											
4HEMG 060 200 S06	6	20	60	6											
4HEMG 080 200 S08	8	20	60	8											
4HEMG 080 250 S08	8	25	70	8											
4HEMG 100 220 S10	10	22	70	10											
4HEMG 100 300 S10	10	30	80	10											
4HEMG 120 260 S12	12	26	75	12											
4HEMG 120 400 S12	12	40	90	12											
4HEMG 120 500 S12	12	50	100	12											
4HEMG 160 350 S16	16	35	90	16											
4HEMG 160 500 S16	16	50	110	16											
4HEMG 200 400 S20	20	40	100	20											
4HEMG 200 500 S20	20	50	110	20											

G series

2날 범용 리브코너 레디우스 엔드밀

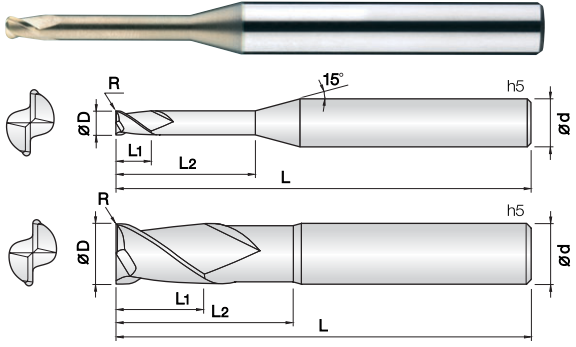

- 중저경도강(HRc52이하), 프리하든강 계열, 탄소강, 금형강 등 가공
- JCRO 코팅 처리하여 넓은 영역의 피삭재 가공에 적합합니다.
- 고정밀 공차 적용으로 초정밀 가공에 적합합니다.
- 코너R 형상을 날부치핑이 적도록 설계하였습니다.
- 다양한 코너R과 유효장으로 맞춤 가공이 가능합니다.
- 항절력이 높은 미립자 초경합금(0.5 μ m)을 채택, 엔드밀의 파손을 최소화
- Endmills for various work materials(~HRc52), pre-hardened steel, carbon steel, mold steel.
- Optimum for various work materials by JCRO coating.
- High precise edge tolerance.
- Designed for minimizing edge chipping by corner R shape.
- Various corner R and flute length for wide range application.
- Minimize fracturing by high TRS fine(0.5 μ m) WC grade.



D Size	D Tolerance
Ø0.2 ~ 5	+0 ~ -0.01mm
Ø6 ~ 12	-0.005 ~ -0.015mm
Ø16	-0.01 ~ -0.02mm

단위 : mm

Order Number	날경 Diameter D×R	날장 Length of cut L1	유효장 Effective Length L2	전장 Overall Length L	샙크 Shank Dia d	비고	Order Number	날경 Diameter D×R	날장 Length of cut L1	유효장 Effective Length L2	전장 Overall Length L	샙크 Shank Dia d	비고
2CREG 002 0002 010	0.2 X R0.02	0.2	1	40	4		2CREG 008 001 080	0.8 X R0.1	0.9	8	45	4	
2CREG 002 0002 015	0.2 X R0.02	0.2	1.5	40	4		2CREG 008 002 020	0.8 X R0.2	0.9	2	45	4	
2CREG 002 0005 010	0.2 X R0.05	0.2	1	40	4		2CREG 008 002 040	0.8 X R0.2	0.9	4	45	4	
2CREG 002 0005 015	0.2 X R0.05	0.2	1.5	40	4		2CREG 008 002 060	0.8 X R0.2	0.9	6	45	4	
2CREG 003 0005 010	0.3 X R0.05	0.3	1	40	4		2CREG 008 002 080	0.8 X R0.2	0.9	8	45	4	
2CREG 003 0005 020	0.3 X R0.05	0.3	2	40	4		2CREG 010 001 040	1 X R0.1	1.2	4	45	4	
2CREG 003 0005 030	0.3 X R0.05	0.3	3	40	4		2CREG 010 001 060	1 X R0.1	1.2	6	45	4	
2CREG 004 0005 010	0.4 X R0.05	0.5	1	40	4		2CREG 010 001 080	1 X R0.1	1.2	8	45	4	
2CREG 004 0005 020	0.4 X R0.05	0.5	2	40	4		2CREG 010 001 100	1 X R0.1	1.2	10	50	4	
2CREG 004 0005 030	0.4 X R0.05	0.5	3	40	4		2CREG 010 001 120	1 X R0.1	1.2	12	50	4	
2CREG 004 0005 040	0.4 X R0.05	0.5	4	40	4		2CREG 010 001 160	1 X R0.1	1.2	16	50	4	
2CREG 004 001 010	0.4 X R0.1	0.5	1	40	4		2CREG 010 001 200	1 X R0.1	1.2	20	50	4	
2CREG 004 001 015	0.4 X R0.1	0.5	1.5	40	4		2CREG 010 002 040	1 X R0.2	1.2	4	45	4	
2CREG 004 001 020	0.4 X R0.1	0.5	2	40	4		2CREG 010 002 060	1 X R0.2	1.2	6	45	4	
2CREG 004 001 030	0.4 X R0.1	0.5	3	40	4		2CREG 010 002 080	1 X R0.2	1.2	8	45	4	
2CREG 004 001 040	0.4 X R0.1	0.5	4	40	4		2CREG 010 002 100	1 X R0.2	1.2	10	50	4	
2CREG 005 0005 010	0.5 X R0.05	0.6	1	45	4		2CREG 010 002 120	1 X R0.2	1.2	12	50	4	
2CREG 005 0005 015	0.5 X R0.05	0.6	1.5	45	4		2CREG 010 002 160	1 X R0.2	1.2	16	50	4	
2CREG 005 0005 020	0.5 X R0.05	0.6	2	45	4		2CREG 010 002 200	1 X R0.2	1.2	20	50	4	
2CREG 005 0005 025	0.5 X R0.05	0.6	2.5	45	4		2CREG 010 003 040	1 X R0.3	1.2	4	45	4	
2CREG 005 0005 030	0.5 X R0.05	0.6	3	45	4		2CREG 010 003 060	1 X R0.3	1.2	6	45	4	
2CREG 005 0005 040	0.5 X R0.05	0.6	4	45	4		2CREG 010 003 080	1 X R0.3	1.2	8	45	4	
2CREG 005 0005 050	0.5 X R0.05	0.6	5	45	4		2CREG 010 003 100	1 X R0.3	1.2	10	50	4	
2CREG 005 0005 060	0.5 X R0.05	0.6	6	45	4		2CREG 010 003 120	1 X R0.3	1.2	12	50	4	
2CREG 005 001 010	0.5 X R0.1	0.6	1	45	4		2CREG 010 003 160	1 X R0.3	1.2	16	50	4	
2CREG 005 001 015	0.5 X R0.1	0.6	1.5	45	4		2CREG 010 003 200	1 X R0.3	1.2	20	50	4	
2CREG 005 001 020	0.5 X R0.1	0.6	2	45	4		2CREG 012 001 040	1.2 X R0.1	1.4	4	45	4	
2CREG 005 001 025	0.5 X R0.1	0.6	2.5	45	4		2CREG 012 001 060	1.2 X R0.1	1.4	6	45	4	
2CREG 005 001 030	0.5 X R0.1	0.6	3	45	4		2CREG 012 001 080	1.2 X R0.1	1.4	8	45	4	
2CREG 005 001 040	0.5 X R0.1	0.6	4	45	4		2CREG 012 001 100	1.2 X R0.1	1.4	10	50	4	
2CREG 005 001 050	0.5 X R0.1	0.6	5	45	4		2CREG 012 001 120	1.2 X R0.1	1.4	12	50	4	
2CREG 005 001 060	0.5 X R0.1	0.6	6	45	4		2CREG 012 001 160	1.2 X R0.1	1.4	16	50	4	
2CREG 006 0005 020	0.6 X R0.05	0.7	2	45	4		2CREG 012 001 200	1.2 X R0.1	1.4	20	50	4	
2CREG 006 0005 030	0.6 X R0.05	0.7	3	45	4		2CREG 012 002 040	1.2 X R0.2	1.4	4	45	4	
2CREG 006 0005 040	0.6 X R0.05	0.7	4	45	4		2CREG 012 002 060	1.2 X R0.2	1.4	6	45	4	
2CREG 006 0005 060	0.6 X R0.05	0.7	6	45	4		2CREG 012 002 080	1.2 X R0.2	1.4	8	45	4	
2CREG 006 0005 080	0.6 X R0.05	0.7	8	45	4		2CREG 012 002 100	1.2 X R0.2	1.4	10	50	4	
2CREG 006 001 020	0.6 X R0.1	0.7	2	45	4		2CREG 012 002 120	1.2 X R0.2	1.4	12	50	4	
2CREG 006 001 030	0.6 X R0.1	0.7	3	45	4		2CREG 012 002 160	1.2 X R0.2	1.4	16	50	4	
2CREG 006 001 040	0.6 X R0.1	0.7	4	45	4		2CREG 012 002 200	1.2 X R0.2	1.4	20	50	4	
2CREG 006 001 060	0.6 X R0.1	0.7	6	45	4		2CREG 012 003 040	1.2 X R0.3	1.4	4	45	4	
2CREG 006 001 080	0.6 X R0.1	0.7	8	45	4		2CREG 012 003 060	1.2 X R0.3	1.4	6	45	4	
2CREG 007 001 020	0.7 X R0.1	0.8	2	45	4		2CREG 012 003 080	1.2 X R0.3	1.4	8	45	4	
2CREG 007 001 040	0.7 X R0.1	0.8	4	45	4		2CREG 012 003 100	1.2 X R0.3	1.4	10	50	4	
2CREG 007 001 060	0.7 X R0.1	0.8	6	45	4		2CREG 012 003 120	1.2 X R0.3	1.4	12	50	4	
2CREG 008 001 020	0.8 X R0.1	0.9	2	45	4		2CREG 012 003 160	1.2 X R0.3	1.4	16	50	4	
2CREG 008 001 040	0.8 X R0.1	0.9	4	45	4		2CREG 012 003 200	1.2 X R0.3	1.4	20	50	4	
2CREG 008 001 060	0.8 X R0.1	0.9	6	45	4		2CREG 015 001 040	1.5 X R0.1	1.8	4	45	4	

단위 : mm

Order Number	날경 D × R	날장 Length of cut L1	유효장 Effective Length L2	전장 Overall Length L	샙크 Shank Dia d	비고	Order Number	날경 D × R	날장 Length of cut L1	유효장 Effective Length L2	전장 Overall Length L	샙크 Shank Dia d	비고
2CREG 015 001 060	1.5 X R0.1	1.8	6	45	4		2CREG 020 005 160	2 X R0.5	2.4	16	50	4	
2CREG 015 001 080	1.5 X R0.1	1.8	8	45	4		2CREG 020 005 200	2 X R0.5	2.4	20	50	4	
2CREG 015 001 100	1.5 X R0.1	1.8	10	50	4		2CREG 020 005 250	2 X R0.5	2.4	25	60	4	
2CREG 015 001 120	1.5 X R0.1	1.8	12	50	4		2CREG 020 005 300	2 X R0.5	2.4	30	70	4	
2CREG 015 001 160	1.5 X R0.1	1.8	16	50	4		2CREG 025 001 100	2.5 X R0.1	3	10	50	4	
2CREG 015 001 200	1.5 X R0.1	1.8	20	50	4		2CREG 025 001 160	2.5 X R0.1	3	16	50	4	
2CREG 015 001 220	1.5 X R0.1	1.8	22	60	4		2CREG 025 001 200	2.5 X R0.1	3	20	50	4	
2CREG 015 001 250	1.5 X R0.1	1.8	25	60	4		2CREG 025 001 250	2.5 X R0.1	3	25	60	4	
2CREG 015 002 040	1.5 X R0.2	1.8	4	45	4		2CREG 025 001 300	2.5 X R0.1	3	30	70	4	
2CREG 015 002 060	1.5 X R0.2	1.8	6	45	4		2CREG 025 002 100	2.5 X R0.2	3	10	50	4	
2CREG 015 002 080	1.5 X R0.2	1.8	8	45	4		2CREG 025 002 160	2.5 X R0.2	3	16	50	4	
2CREG 015 002 100	1.5 X R0.2	1.8	10	50	4		2CREG 025 002 200	2.5 X R0.2	3	20	50	4	
2CREG 015 002 120	1.5 X R0.2	1.8	12	50	4		2CREG 025 002 250	2.5 X R0.2	3	25	60	4	
2CREG 015 002 160	1.5 X R0.2	1.8	16	50	4		2CREG 025 002 300	2.5 X R0.2	3	30	70	4	
2CREG 015 002 200	1.5 X R0.2	1.8	20	50	4		2CREG 025 003 100	2.5 X R0.3	3	10	50	4	
2CREG 015 002 220	1.5 X R0.2	1.8	22	60	4		2CREG 025 003 160	2.5 X R0.3	3	16	50	4	
2CREG 015 002 250	1.5 X R0.2	1.8	25	60	4		2CREG 025 003 200	2.5 X R0.3	3	20	50	4	
2CREG 015 003 040	1.5 X R0.3	1.8	4	45	4		2CREG 025 003 250	2.5 X R0.3	3	25	60	4	
2CREG 015 003 060	1.5 X R0.3	1.8	6	45	4		2CREG 025 003 300	2.5 X R0.3	3	30	70	4	
2CREG 015 003 080	1.5 X R0.3	1.8	8	45	4		2CREG 025 005 100	2.5 X R0.5	3	10	50	4	
2CREG 015 003 100	1.5 X R0.3	1.8	10	50	4		2CREG 025 005 160	2.5 X R0.5	3	16	50	4	
2CREG 015 003 120	1.5 X R0.3	1.8	12	50	4		2CREG 025 005 200	2.5 X R0.5	3	20	50	4	
2CREG 015 003 160	1.5 X R0.3	1.8	16	50	4		2CREG 025 005 250	2.5 X R0.5	3	25	60	4	
2CREG 015 003 200	1.5 X R0.3	1.8	20	50	4		2CREG 025 005 300	2.5 X R0.5	3	30	70	4	
2CREG 015 003 220	1.5 X R0.3	1.8	22	60	4		2CREG 030 001 100	3 X R0.1	3.6	10	50	6	
2CREG 015 003 250	1.5 X R0.3	1.8	25	60	4		2CREG 030 001 120	3 X R0.1	3.6	12	50	6	
2CREG 015 005 040	1.5 X R0.5	1.8	4	45	4		2CREG 030 001 160	3 X R0.1	3.6	16	55	6	
2CREG 015 005 060	1.5 X R0.5	1.8	6	45	4		2CREG 030 001 200	3 X R0.1	3.6	20	60	6	
2CREG 015 005 080	1.5 X R0.5	1.8	8	45	4		2CREG 030 001 250	3 X R0.1	3.6	25	65	6	
2CREG 015 005 100	1.5 X R0.5	1.8	10	50	4		2CREG 030 001 300	3 X R0.1	3.6	30	70	6	
2CREG 015 005 120	1.5 X R0.5	1.8	12	50	4		2CREG 030 001 350	3 X R0.1	3.6	35	75	6	
2CREG 015 005 160	1.5 X R0.5	1.8	16	50	4		2CREG 030 001 400	3 X R0.1	3.6	40	80	6	
2CREG 015 005 200	1.5 X R0.5	1.8	20	50	4		2CREG 030 002 100	3 X R0.2	3.6	10	50	6	
2CREG 015 005 220	1.5 X R0.5	1.8	22	60	4		2CREG 030 002 120	3 X R0.2	3.6	12	50	6	
2CREG 015 005 250	1.5 X R0.5	1.8	25	60	4		2CREG 030 002 160	3 X R0.2	3.6	16	55	6	
2CREG 020 001 060	2 X R0.1	2.4	6	45	4		2CREG 030 002 200	3 X R0.2	3.6	20	60	6	
2CREG 020 001 080	2 X R0.1	2.4	8	45	4		2CREG 030 002 250	3 X R0.2	3.6	25	65	6	
2CREG 020 001 100	2 X R0.1	2.4	10	50	4		2CREG 030 002 300	3 X R0.2	3.6	30	70	6	
2CREG 020 001 120	2 X R0.1	2.4	12	50	4		2CREG 030 002 350	3 X R0.2	3.6	35	75	6	
2CREG 020 001 160	2 X R0.1	2.4	16	50	4		2CREG 030 002 400	3 X R0.2	3.6	40	80	6	
2CREG 020 001 200	2 X R0.1	2.4	20	50	4		2CREG 030 003 100	3 X R0.3	3.6	10	50	6	
2CREG 020 001 250	2 X R0.1	2.4	25	60	4		2CREG 030 003 120	3 X R0.3	3.6	12	50	6	
2CREG 020 001 300	2 X R0.1	2.4	30	70	4		2CREG 030 003 160	3 X R0.3	3.6	16	55	6	
2CREG 020 002 060	2 X R0.2	2.4	6	45	4		2CREG 030 003 200	3 X R0.3	3.6	20	60	6	
2CREG 020 002 080	2 X R0.2	2.4	8	45	4		2CREG 030 003 250	3 X R0.3	3.6	25	65	6	
2CREG 020 002 100	2 X R0.2	2.4	10	50	4		2CREG 030 003 300	3 X R0.3	3.6	30	70	6	
2CREG 020 002 120	2 X R0.2	2.4	12	50	4		2CREG 030 003 350	3 X R0.3	3.6	35	75	6	
2CREG 020 002 160	2 X R0.2	2.4	16	50	4		2CREG 030 003 400	3 X R0.3	3.6	40	80	6	
2CREG 020 002 200	2 X R0.2	2.4	20	50	4		2CREG 030 005 100	3 X R0.5	3.6	10	50	6	
2CREG 020 002 250	2 X R0.2	2.4	25	60	4		2CREG 030 005 120	3 X R0.5	3.6	12	50	6	
2CREG 020 002 300	2 X R0.2	2.4	30	70	4		2CREG 030 005 160	3 X R0.5	3.6	16	55	6	
2CREG 020 003 060	2 X R0.3	2.4	6	45	4		2CREG 030 005 200	3 X R0.5	3.6	20	60	6	
2CREG 020 003 080	2 X R0.3	2.4	8	45	4		2CREG 030 005 250	3 X R0.5	3.6	25	65	6	
2CREG 020 003 100	2 X R0.3	2.4	10	50	4		2CREG 030 005 300	3 X R0.5	3.6	30	70	6	
2CREG 020 003 120	2 X R0.3	2.4	12	50	4		2CREG 030 005 350	3 X R0.5	3.6	35	75	6	
2CREG 020 003 160	2 X R0.3	2.4	16	50	4		2CREG 030 005 400	3 X R0.5	3.6	40	80	6	
2CREG 020 003 200	2 X R0.3	2.4	20	50	4		2CREG 030 010 100	3 X R1	3.6	10	50	6	
2CREG 020 003 250	2 X R0.3	2.4	25	60	4		2CREG 030 010 120	3 X R1	3.6	12	50	6	
2CREG 020 003 300	2 X R0.3	2.4	30	70	4		2CREG 030 010 160	3 X R1	3.6	16	55	6	
2CREG 020 005 060	2 X R0.5	2.4	6	45	4		2CREG 030 010 200	3 X R1	3.6	20	60	6	
2CREG 020 005 080	2 X R0.5	2.4	8	45	4		2CREG 030 010 250	3 X R1	3.6	25	65	6	
2CREG 020 005 100	2 X R0.5	2.4	10	50	4		2CREG 030 010 300	3 X R1	3.6	30	70	6	
2CREG 020 005 120	2 X R0.5	2.4	12	50	4		2CREG 030 010 350	3 X R1	3.6	35	75	6	

단위 : mm

Order Number	날경 D×R	날장 L1	유효장 Effective Length L2	전장 Overall Length L	샙크 Shank Dia d	비고	Order Number	날경 D×R	날장 L1	유효장 Effective Length L2	전장 Overall Length L	샙크 Shank Dia d	비고
2CREG 030 010 400	3 X R1	3.6	40	80	6		2CREG 050 005 300	5 X R0.5	6	30	70	6	
2CREG 040 001 050	4 X R0.1	4.8	12	50	4		2CREG 050 005 400	5 X R0.5	6	40	80	6	
2CREG 040 001 070	4 X R0.1	4.8	20	70	4		2CREG 050 005 500	5 X R0.5	6	50	100	6	
2CREG 040 001 120	4 X R0.1	4.8	12	50	6		2CREG 050 010 150	5 X R1	6	15	55	6	
2CREG 040 001 160	4 X R0.1	4.8	16	55	6		2CREG 050 010 250	5 X R1	6	25	70	6	
2CREG 040 001 200	4 X R0.1	4.8	20	60	6		2CREG 050 010 300	5 X R1	6	30	70	6	
2CREG 040 001 250	4 X R0.1	4.8	25	65	6		2CREG 050 010 400	5 X R1	6	40	80	6	
2CREG 040 001 300	4 X R0.1	4.8	30	70	6		2CREG 050 010 500	5 X R1	6	50	100	6	
2CREG 040 001 350	4 X R0.1	4.8	35	75	6		2CREG 060 001 200	6 X R0.1	7	20	60	6	
2CREG 040 001 400	4 X R0.1	4.8	40	80	6		2CREG 060 001 400	6 X R0.1	7	40	90	6	
2CREG 040 001 450	4 X R0.1	4.8	45	90	6		2CREG 060 002 200	6 X R0.2	7	20	60	6	
2CREG 040 001 500	4 X R0.1	4.8	50	100	6		2CREG 060 002 400	6 X R0.2	7	40	90	6	
2CREG 040 002 050	4 X R0.2	4.8	12	50	4		2CREG 060 003 200	6 X R0.3	7	20	60	6	
2CREG 040 002 070	4 X R0.2	4.8	20	70	4		2CREG 060 003 400	6 X R0.3	7	40	90	6	
2CREG 040 002 120	4 X R0.2	4.8	12	50	6		2CREG 060 005 200	6 X R0.5	7	20	60	6	
2CREG 040 002 160	4 X R0.2	4.8	16	55	6		2CREG 060 005 400	6 X R0.5	7	40	90	6	
2CREG 040 002 200	4 X R0.2	4.8	20	60	6		2CREG 060 010 200	6 X R1	7	20	60	6	
2CREG 040 002 250	4 X R0.2	4.8	25	65	6		2CREG 060 010 400	6 X R1	7	40	90	6	
2CREG 040 002 300	4 X R0.2	4.8	30	70	6		2CREG 060 015 200	6 X R1.5	7	20	60	6	
2CREG 040 002 350	4 X R0.2	4.8	35	75	6		2CREG 060 015 400	6 X R1.5	7	40	90	6	
2CREG 040 002 400	4 X R0.2	4.8	40	80	6		2CREG 080 002 220	8 X R0.2	9	22	65	8	
2CREG 040 002 450	4 X R0.2	4.8	45	90	6		2CREG 080 002 400	8 X R0.2	9	40	100	8	
2CREG 040 002 500	4 X R0.2	4.8	50	100	6		2CREG 080 003 220	8 X R0.3	9	22	65	8	
2CREG 040 003 050	4 X R0.3	4.8	12	50	4		2CREG 080 003 400	8 X R0.3	9	40	100	8	
2CREG 040 003 070	4 X R0.3	4.8	20	70	4		2CREG 080 005 220	8 X R0.5	9	22	65	8	
2CREG 040 003 120	4 X R0.3	4.8	12	50	6		2CREG 080 005 400	8 X R0.5	9	40	100	8	
2CREG 040 003 160	4 X R0.3	4.8	16	55	6		2CREG 080 010 220	8 X R1	9	22	65	8	
2CREG 040 003 200	4 X R0.3	4.8	20	60	6		2CREG 080 010 400	8 X R1	9	40	100	8	
2CREG 040 003 250	4 X R0.3	4.8	25	65	6		2CREG 080 015 220	8 X R1.5	9	22	65	8	
2CREG 040 003 300	4 X R0.3	4.8	30	70	6		2CREG 080 015 400	8 X R1.5	9	40	100	8	
2CREG 040 003 350	4 X R0.3	4.8	35	75	6		2CREG 100 002 240	10 X R0.2	11	24	70	10	
2CREG 040 003 400	4 X R0.3	4.8	40	80	6		2CREG 100 002 450	10 X R0.2	11	45	100	10	
2CREG 040 003 450	4 X R0.3	4.8	45	90	6		2CREG 100 003 240	10 X R0.3	11	24	70	10	
2CREG 040 003 500	4 X R0.3	4.8	50	100	6		2CREG 100 003 450	10 X R0.3	11	45	100	10	
2CREG 040 005 050	4 X R0.5	4.8	12	50	4		2CREG 100 005 240	10 X R0.5	11	24	70	10	
2CREG 040 005 070	4 X R0.5	4.8	20	70	4		2CREG 100 005 450	10 X R0.5	11	45	100	10	
2CREG 040 005 120	4 X R0.5	4.8	12	50	6		2CREG 100 010 240	10 X R1	11	24	70	10	
2CREG 040 005 160	4 X R0.5	4.8	16	55	6		2CREG 100 010 450	10 X R1	11	45	100	10	
2CREG 040 005 200	4 X R0.5	4.8	20	60	6		2CREG 100 015 240	10 X R1.5	11	24	70	10	
2CREG 040 005 250	4 X R0.5	4.8	25	65	6		2CREG 100 015 450	10 X R1.5	11	45	100	10	
2CREG 040 005 300	4 X R0.5	4.8	30	70	6		2CREG 100 020 240	10 X R2	11	24	70	10	
2CREG 040 005 350	4 X R0.5	4.8	35	75	6		2CREG 100 020 450	10 X R2	11	45	100	10	
2CREG 040 005 400	4 X R0.5	4.8	40	80	6		2CREG 120 002 260	12 X R0.2	13	26	80	12	
2CREG 040 005 450	4 X R0.5	4.8	45	90	6		2CREG 120 002 500	12 X R0.2	13	50	110	12	
2CREG 040 005 500	4 X R0.5	4.8	50	100	6		2CREG 120 003 260	12 X R0.3	13	26	80	12	
2CREG 040 010 050	4 X R1	4.8	12	50	4		2CREG 120 003 500	12 X R0.3	13	50	110	12	
2CREG 040 010 070	4 X R1	4.8	20	70	4		2CREG 120 005 260	12 X R0.5	13	26	80	12	
2CREG 040 010 120	4 X R1	4.8	12	50	6		2CREG 120 005 500	12 X R0.5	13	50	110	12	
2CREG 040 010 160	4 X R1	4.8	16	55	6		2CREG 120 010 260	12 X R1	13	26	80	12	
2CREG 040 010 200	4 X R1	4.8	20	60	6		2CREG 120 010 500	12 X R1	13	50	110	12	
2CREG 040 010 250	4 X R1	4.8	25	65	6		2CREG 120 015 260	12 X R1.5	13	26	80	12	
2CREG 040 010 300	4 X R1	4.8	30	70	6		2CREG 120 015 500	12 X R1.5	13	50	110	12	
2CREG 040 010 350	4 X R1	4.8	35	75	6		2CREG 120 020 260	12 X R2	13	26	80	12	
2CREG 040 010 400	4 X R1	4.8	40	80	6		2CREG 120 020 500	12 X R2	13	50	110	12	
2CREG 040 010 450	4 X R1	4.8	45	90	6		2CREG 120 030 260	12 X R3	13	26	80	12	
2CREG 040 010 500	4 X R1	4.8	50	100	6		2CREG 120 030 500	12 X R3	13	50	110	12	
2CREG 050 002 150	5 X R0.2	6	15	55	6		2CREG 160 005 110	16 X R0.5	20	35	110	16	
2CREG 050 002 250	5 X R0.2	6	25	70	6		2CREG 160 005 160	16 X R0.5	20	35	160	16	
2CREG 050 002 300	5 X R0.2	6	30	70	6		2CREG 160 010 110	16 X R1	20	35	110	16	
2CREG 050 002 400	5 X R0.2	6	40	80	6		2CREG 160 010 160	16 X R1	20	35	160	16	
2CREG 050 002 500	5 X R0.2	6	50	100	6								
2CREG 050 005 150	5 X R0.5	6	15	55	6								
2CREG 050 005 250	5 X R0.5	6	25	70	6								

G series

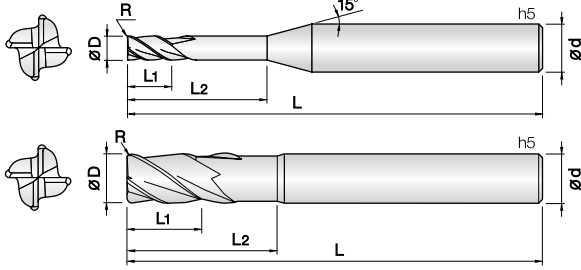

- 중저경도강(HRc52이하), 프리하드강 계열, 탄소강, 금형강 등 가공
- JCRO 코팅 처리하여 넓은 영역의 피삭재 가공에 적합합니다.
- 고정밀 공차 적용으로 초정밀 가공에 적합합니다.
- 코너R 형상을 날부치핑이 적도록 설계하였습니다.
- 다양한 코너R과 유효장으로 맞춤 가공이 가능합니다.
- 항절력이 높은 미립자 초경합금(0.5 μ m)을 채택, 엔드밀의 파손을 최소화
- Endmills for various work materials(~HRc52), pre-hardened steel, carbon steel, mold steel.
- Optimum for various work materials by JCROcoating.
- Designed for minimizing edge chipping by corner R shape.
- Various corner R and flute length for wide range application.
- High precise edge tolerance.
- Minimize fracturing by high TRS fine(0.5 μ m) WC grade.

4

WC
미립자

JCRO
Coating

R
±0.005

R
±0.01

R
±0.015

35°
Helix Angle

R0.05 ~ 0.5 R1 ~ 1.5 R2 ~ 3

D Size	D Tolerance
Ø1 ~ 5	+0 ~ -0.01mm
Ø6 ~ 12	-0.005 ~ -0.015mm

단위 : mm

Order Number	날경 Diameter D x R	날장 Length of cut L1	유효장 Effective Length L2	전장 Overall Length L	샙크 Shank Dia d	비고	Order Number	날경 Diameter D x R	날장 Length of cut L1	유효장 Effective Length L2	전장 Overall Length L	샙크 Shank Dia d	비고
4CREG 010 0005 040	1 X R0.05	1.2	4	45	4		4CREG 012 003 200	1.2 X R0.3	1.4	20	50	4	
4CREG 010 0005 060	1 X R0.05	1.2	6	45	4		4CREG 015 001 060	1.5 X R0.1	1.8	6	45	4	
4CREG 010 0005 080	1 X R0.05	1.2	8	45	4		4CREG 015 001 080	1.5 X R0.1	1.8	8	45	4	
4CREG 010 0005 100	1 X R0.05	1.2	10	50	4		4CREG 015 001 100	1.5 X R0.1	1.8	10	50	4	
4CREG 010 0005 120	1 X R0.05	1.2	12	50	4		4CREG 015 001 120	1.5 X R0.1	1.8	12	50	4	
4CREG 010 0005 160	1 X R0.05	1.2	16	50	4		4CREG 015 001 160	1.5 X R0.1	1.8	16	50	4	
4CREG 010 0005 200	1 X R0.05	1.2	20	50	4		4CREG 015 001 200	1.5 X R0.1	1.8	20	50	4	
4CREG 010 001 040	1 X R0.1	1.2	4	45	4		4CREG 015 001 220	1.5 X R0.1	1.8	22	60	4	
4CREG 010 001 060	1 X R0.1	1.2	6	45	4		4CREG 015 001 250	1.5 X R0.1	1.8	25	60	4	
4CREG 010 001 080	1 X R0.1	1.2	8	45	4		4CREG 015 002 060	1.5 X R0.2	1.8	6	45	4	
4CREG 010 001 100	1 X R0.1	1.2	10	50	4		4CREG 015 002 080	1.5 X R0.2	1.8	8	45	4	
4CREG 010 001 120	1 X R0.1	1.2	12	50	4		4CREG 015 002 100	1.5 X R0.2	1.8	10	50	4	
4CREG 010 001 160	1 X R0.1	1.2	16	50	4		4CREG 015 002 120	1.5 X R0.2	1.8	12	50	4	
4CREG 010 001 200	1 X R0.1	1.2	20	50	4		4CREG 015 002 160	1.5 X R0.2	1.8	16	50	4	
4CREG 010 002 040	1 X R0.2	1.2	4	45	4		4CREG 015 002 200	1.5 X R0.2	1.8	20	50	4	
4CREG 010 002 060	1 X R0.2	1.2	6	45	4		4CREG 015 002 220	1.5 X R0.2	1.8	22	60	4	
4CREG 010 002 080	1 X R0.2	1.2	8	45	4		4CREG 015 002 250	1.5 X R0.2	1.8	25	60	4	
4CREG 010 002 100	1 X R0.2	1.2	10	50	4		4CREG 015 003 060	1.5 X R0.3	1.8	6	45	4	
4CREG 010 002 120	1 X R0.2	1.2	12	50	4		4CREG 015 003 080	1.5 X R0.3	1.8	8	45	4	
4CREG 010 002 160	1 X R0.2	1.2	16	50	4		4CREG 015 003 100	1.5 X R0.3	1.8	10	50	4	
4CREG 010 002 200	1 X R0.2	1.2	20	50	4		4CREG 015 003 120	1.5 X R0.3	1.8	12	50	4	
4CREG 010 003 040	1 X R0.3	1.2	4	45	4		4CREG 015 003 160	1.5 X R0.3	1.8	16	50	4	
4CREG 010 003 060	1 X R0.3	1.2	6	45	4		4CREG 015 003 200	1.5 X R0.3	1.8	20	50	4	
4CREG 010 003 080	1 X R0.3	1.2	8	45	4		4CREG 015 003 220	1.5 X R0.3	1.8	22	60	4	
4CREG 010 003 100	1 X R0.3	1.2	10	50	4		4CREG 015 003 250	1.5 X R0.3	1.8	25	60	4	
4CREG 010 003 120	1 X R0.3	1.2	12	50	4		4CREG 015 005 060	1.5 X R0.5	1.8	6	45	4	
4CREG 010 003 160	1 X R0.3	1.2	16	50	4		4CREG 015 005 080	1.5 X R0.5	1.8	8	45	4	
4CREG 010 003 200	1 X R0.3	1.2	20	50	4		4CREG 015 005 100	1.5 X R0.5	1.8	10	50	4	
4CREG 012 001 040	1.2 X R0.1	1.4	4	45	4		4CREG 015 005 120	1.5 X R0.5	1.8	12	50	4	
4CREG 012 001 060	1.2 X R0.1	1.4	6	45	4		4CREG 015 005 160	1.5 X R0.5	1.8	16	50	4	
4CREG 012 001 080	1.2 X R0.1	1.4	8	45	4		4CREG 015 005 200	1.5 X R0.5	1.8	20	50	4	
4CREG 012 001 100	1.2 X R0.1	1.4	10	50	4		4CREG 015 005 220	1.5 X R0.5	1.8	22	60	4	
4CREG 012 001 120	1.2 X R0.1	1.4	12	50	4		4CREG 015 005 250	1.5 X R0.5	1.8	25	60	4	
4CREG 012 001 160	1.2 X R0.1	1.4	16	50	4		4CREG 020 001 060	2 X R0.1	2.4	6	45	4	
4CREG 012 001 200	1.2 X R0.1	1.4	20	50	4		4CREG 020 001 080	2 X R0.1	2.4	8	45	4	
4CREG 012 002 040	1.2 X R0.2	1.4	4	45	4		4CREG 020 001 100	2 X R0.1	2.4	10	50	4	
4CREG 012 002 060	1.2 X R0.2	1.4	6	45	4		4CREG 020 001 120	2 X R0.1	2.4	12	50	4	
4CREG 012 002 080	1.2 X R0.2	1.4	8	45	4		4CREG 020 001 160	2 X R0.1	2.4	16	50	4	
4CREG 012 002 100	1.2 X R0.2	1.4	10	50	4		4CREG 020 001 200	2 X R0.1	2.4	20	50	4	
4CREG 012 002 120	1.2 X R0.2	1.4	12	50	4		4CREG 020 001 250	2 X R0.1	2.4	25	60	4	
4CREG 012 002 160	1.2 X R0.2	1.4	16	50	4		4CREG 020 001 300	2 X R0.1	2.4	30	70	4	
4CREG 012 002 200	1.2 X R0.2	1.4	20	50	4		4CREG 020 001 350	2 X R0.1	2.4	35	70	4	
4CREG 012 003 040	1.2 X R0.3	1.4	4	45	4		4CREG 020 002 060	2 X R0.2	2.4	6	45	4	
4CREG 012 003 060	1.2 X R0.3	1.4	6	45	4		4CREG 020 002 080	2 X R0.2	2.4	8	45	4	
4CREG 012 003 080	1.2 X R0.3	1.4	8	45	4		4CREG 020 002 100	2 X R0.2	2.4	10	50	4	
4CREG 012 003 100	1.2 X R0.3	1.4	10	50	4		4CREG 020 002 120	2 X R0.2	2.4	12	50	4	
4CREG 012 003 120	1.2 X R0.3	1.4	12	50	4		4CREG 020 002 160	2 X R0.2	2.4	16	50	4	
4CREG 012 003 160	1.2 X R0.3	1.4	16	50	4		4CREG 020 002 200	2 X R0.2	2.4	20	50	4	

단위 : mm

Order Number	날경 D×R	날장 L1	유효장 Effective Length L2	전장 Overall Length L	샙크 Shank Dia d	비고	Order Number	날경 D×R	날장 L1	유효장 Effective Length L2	전장 Overall Length L	샙크 Shank Dia d	비고
4CREG 020 002 250	2 X R0.2	2.4	25	60	4		4CREG 030 003 400	3 X R0.3	3.6	40	80	6	
4CREG 020 002 300	2 X R0.2	2.4	30	70	4		4CREG 030 003 500	3 X R0.3	3.6	50	100	6	
4CREG 020 002 350	2 X R0.2	2.4	35	70	4		4CREG 030 005 100	3 X R0.5	3.6	10	50	6	
4CREG 020 003 060	2 X R0.3	2.4	6	45	4		4CREG 030 005 160	3 X R0.5	3.6	16	55	6	
4CREG 020 003 080	2 X R0.3	2.4	8	45	4		4CREG 030 005 200	3 X R0.5	3.6	20	60	6	
4CREG 020 003 100	2 X R0.3	2.4	10	50	4		4CREG 030 005 250	3 X R0.5	3.6	25	65	6	
4CREG 020 003 120	2 X R0.3	2.4	12	50	4		4CREG 030 005 300	3 X R0.5	3.6	30	70	6	
4CREG 020 003 160	2 X R0.3	2.4	16	50	4		4CREG 030 005 350	3 X R0.5	3.6	35	75	6	
4CREG 020 003 200	2 X R0.3	2.4	20	50	4		4CREG 030 005 400	3 X R0.5	3.6	40	80	6	
4CREG 020 003 250	2 X R0.3	2.4	25	60	4		4CREG 030 005 500	3 X R0.5	3.6	50	100	6	
4CREG 020 003 300	2 X R0.3	2.4	30	70	4		4CREG 030 010 100	3 X R1	3.6	10	50	6	
4CREG 020 003 350	2 X R0.3	2.4	35	70	4		4CREG 030 010 160	3 X R1	3.6	16	55	6	
4CREG 020 005 060	2 X R0.5	2.4	6	45	4		4CREG 030 010 200	3 X R1	3.6	20	60	6	
4CREG 020 005 080	2 X R0.5	2.4	8	45	4		4CREG 030 010 250	3 X R1	3.6	25	65	6	
4CREG 020 005 100	2 X R0.5	2.4	10	50	4		4CREG 030 010 300	3 X R1	3.6	30	70	6	
4CREG 020 005 120	2 X R0.5	2.4	12	50	4		4CREG 030 010 350	3 X R1	3.6	35	75	6	
4CREG 020 005 160	2 X R0.5	2.4	16	50	4		4CREG 030 010 400	3 X R1	3.6	40	80	6	
4CREG 020 005 200	2 X R0.5	2.4	20	50	4		4CREG 030 010 500	3 X R1	3.6	50	100	6	
4CREG 020 005 250	2 X R0.5	2.4	25	60	4		4CREG 040 001 050	4 X R0.1	4.8	12	50	4	
4CREG 020 005 300	2 X R0.5	2.4	30	70	4		4CREG 040 001 070	4 X R0.1	4.8	20	70	4	
4CREG 020 005 350	2 X R0.5	2.4	35	70	4		4CREG 040 001 120	4 X R0.1	4.8	12	50	6	
4CREG 025 001 100	2.5 X R0.1	3	10	50	4		4CREG 040 001 160	4 X R0.1	4.8	16	55	6	
4CREG 025 001 160	2.5 X R0.1	3	16	50	4		4CREG 040 001 200	4 X R0.1	4.8	20	60	6	
4CREG 025 001 200	2.5 X R0.1	3	20	50	4		4CREG 040 001 250	4 X R0.1	4.8	25	65	6	
4CREG 025 001 250	2.5 X R0.1	3	25	60	4		4CREG 040 001 300	4 X R0.1	4.8	30	70	6	
4CREG 025 001 300	2.5 X R0.1	3	30	70	4		4CREG 040 001 350	4 X R0.1	4.8	35	75	6	
4CREG 025 002 100	2.5 X R0.2	3	10	50	4		4CREG 040 001 400	4 X R0.1	4.8	40	80	6	
4CREG 025 002 160	2.5 X R0.2	3	16	50	4		4CREG 040 001 450	4 X R0.1	4.8	45	90	6	
4CREG 025 002 200	2.5 X R0.2	3	20	50	4		4CREG 040 001 500	4 X R0.1	4.8	50	100	6	
4CREG 025 002 250	2.5 X R0.2	3	25	60	4		4CREG 040 002 050	4 X R0.2	4.8	12	50	4	
4CREG 025 002 300	2.5 X R0.2	3	30	70	4		4CREG 040 002 070	4 X R0.2	4.8	20	70	4	
4CREG 025 003 100	2.5 X R0.3	3	10	50	4		4CREG 040 002 120	4 X R0.2	4.8	12	50	6	
4CREG 025 003 160	2.5 X R0.3	3	16	50	4		4CREG 040 002 160	4 X R0.2	4.8	16	55	6	
4CREG 025 003 200	2.5 X R0.3	3	20	50	4		4CREG 040 002 200	4 X R0.2	4.8	20	60	6	
4CREG 025 003 250	2.5 X R0.3	3	25	60	4		4CREG 040 002 250	4 X R0.2	4.8	25	65	6	
4CREG 025 003 300	2.5 X R0.3	3	30	70	4		4CREG 040 002 300	4 X R0.2	4.8	30	70	6	
4CREG 025 005 100	2.5 X R0.5	3	10	50	4		4CREG 040 002 350	4 X R0.2	4.8	35	75	6	
4CREG 025 005 160	2.5 X R0.5	3	16	50	4		4CREG 040 002 400	4 X R0.2	4.8	40	80	6	
4CREG 025 005 200	2.5 X R0.5	3	20	50	4		4CREG 040 002 450	4 X R0.2	4.8	45	90	6	
4CREG 025 005 250	2.5 X R0.5	3	25	60	4		4CREG 040 002 500	4 X R0.2	4.8	50	100	6	
4CREG 025 005 300	2.5 X R0.5	3	30	70	4		4CREG 040 003 050	4 X R0.3	4.8	12	50	4	
4CREG 030 001 100	3 X R0.1	3.6	10	50	6		4CREG 040 003 070	4 X R0.3	4.8	20	70	4	
4CREG 030 001 160	3 X R0.1	3.6	16	55	6		4CREG 040 003 120	4 X R0.3	4.8	12	50	6	
4CREG 030 001 200	3 X R0.1	3.6	20	60	6		4CREG 040 003 160	4 X R0.3	4.8	16	55	6	
4CREG 030 001 250	3 X R0.1	3.6	25	65	6		4CREG 040 003 200	4 X R0.3	4.8	20	60	6	
4CREG 030 001 300	3 X R0.1	3.6	30	70	6		4CREG 040 003 250	4 X R0.3	4.8	25	65	6	
4CREG 030 001 350	3 X R0.1	3.6	35	75	6		4CREG 040 003 300	4 X R0.3	4.8	30	70	6	
4CREG 030 001 400	3 X R0.1	3.6	40	80	6		4CREG 040 003 350	4 X R0.3	4.8	35	75	6	
4CREG 030 001 500	3 X R0.1	3.6	50	100	6		4CREG 040 003 400	4 X R0.3	4.8	40	80	6	
4CREG 030 002 100	3 X R0.2	3.6	10	50	6		4CREG 040 003 450	4 X R0.3	4.8	45	90	6	
4CREG 030 002 160	3 X R0.2	3.6	16	55	6		4CREG 040 003 500	4 X R0.3	4.8	50	100	6	
4CREG 030 002 200	3 X R0.2	3.6	20	60	6		4CREG 040 005 050	4 X R0.5	4.8	12	50	4	
4CREG 030 002 250	3 X R0.2	3.6	25	65	6		4CREG 040 005 070	4 X R0.5	4.8	20	70	4	
4CREG 030 002 300	3 X R0.2	3.6	30	70	6		4CREG 040 005 120	4 X R0.5	4.8	12	50	6	
4CREG 030 002 350	3 X R0.2	3.6	35	75	6		4CREG 040 005 160	4 X R0.5	4.8	16	55	6	
4CREG 030 002 400	3 X R0.2	3.6	40	80	6		4CREG 040 005 200	4 X R0.5	4.8	20	60	6	
4CREG 030 002 500	3 X R0.2	3.6	50	100	6		4CREG 040 005 250	4 X R0.5	4.8	25	65	6	
4CREG 030 003 100	3 X R0.3	3.6	10	50	6		4CREG 040 005 300	4 X R0.5	4.8	30	70	6	
4CREG 030 003 160	3 X R0.3	3.6	16	55	6		4CREG 040 005 350	4 X R0.5	4.8	35	75	6	
4CREG 030 003 200	3 X R0.3	3.6	20	60	6		4CREG 040 005 400	4 X R0.5	4.8	40	80	6	
4CREG 030 003 250	3 X R0.3	3.6	25	65	6		4CREG 040 005 450	4 X R0.5	4.8	45	90	6	
4CREG 030 003 300	3 X R0.3	3.6	30	70	6		4CREG 040 005 500	4 X R0.5	4.8	50	100	6	
4CREG 030 003 350	3 X R0.3	3.6	35	75	6		4CREG 040 010 050	4 X R1	4.8	12	50	4	

G series

단위 : mm

Order Number	날경 Diameter D x R	날장 Length of cut L1	유효장 Effective Length L2	전장 Overall Length L	샙크 Shank Dia d	비고	Order Number	날경 Diameter D x R	날장 Length of cut L1	유효장 Effective Length L2	전장 Overall Length L	샙크 Shank Dia d	비고
4CREG 040 010 070	4 X R1	4.8	20	70	4		4CREG 100 015 240	10 X R1.5	11	24	70	10	
4CREG 040 010 120	4 X R1	4.8	12	50	6		4CREG 100 015 400	10 X R1.5	11	40	100	10	
4CREG 040 010 160	4 X R1	4.8	16	55	6		4CREG 100 020 240	10 X R2	11	24	70	10	
4CREG 040 010 200	4 X R1	4.8	20	60	6		4CREG 100 025 240	10 X R2.5	11	24	70	10	
4CREG 040 010 250	4 X R1	4.8	25	65	6		4CREG 120 003 260	12 X R0.3	13	26	80	12	
4CREG 040 010 300	4 X R1	4.8	30	70	6		4CREG 120 005 260	12 X R0.5	13	26	80	12	
4CREG 040 010 350	4 X R1	4.8	35	75	6		4CREG 120 005 400	12 X R0.5	13	40	110	12	
4CREG 040 010 400	4 X R1	4.8	40	80	6		4CREG 120 010 260	12 X R1	13	26	80	12	
4CREG 040 010 450	4 X R1	4.8	45	90	6		4CREG 120 010 400	12 X R1	13	40	110	12	
4CREG 040 010 500	4 X R1	4.8	50	100	6		4CREG 120 015 260	12 X R1.5	13	26	80	12	
4CREG 050 001 150	5 X R0.1	6	15	55	6		4CREG 120 015 400	12 X R1.5	13	40	110	12	
4CREG 050 001 300	5 X R0.1	6	30	70	6		4CREG 120 020 260	12 X R2	13	26	80	12	
4CREG 050 001 400	5 X R0.1	6	40	80	6		4CREG 120 030 260	12 X R3	13	26	80	12	
4CREG 050 001 500	5 X R0.1	6	50	100	6								
4CREG 050 002 150	5 X R0.2	6	15	55	6								
4CREG 050 002 300	5 X R0.2	6	30	70	6								
4CREG 050 002 400	5 X R0.2	6	40	80	6								
4CREG 050 002 500	5 X R0.2	6	50	100	6								
4CREG 050 003 150	5 X R0.3	6	15	55	6								
4CREG 050 003 300	5 X R0.3	6	30	70	6								
4CREG 050 003 400	5 X R0.3	6	40	80	6								
4CREG 050 003 500	5 X R0.3	6	50	100	6								
4CREG 050 005 150	5 X R0.5	6	15	55	6								
4CREG 050 005 300	5 X R0.5	6	30	70	6								
4CREG 050 005 400	5 X R0.5	6	40	80	6								
4CREG 050 005 500	5 X R0.5	6	50	100	6								
4CREG 050 010 150	5 X R1	6	15	55	6								
4CREG 050 010 300	5 X R1	6	30	70	6								
4CREG 050 010 400	5 X R1	6	40	80	6								
4CREG 050 010 500	5 X R1	6	50	100	6								
4CREG 060 001 200	6 X R0.1	7	20	60	6								
4CREG 060 001 400	6 X R0.1	7	40	80	6								
4CREG 060 001 500	6 X R0.1	7	50	100	6								
4CREG 060 002 200	6 X R0.2	7	20	60	6								
4CREG 060 002 400	6 X R0.2	7	40	80	6								
4CREG 060 002 500	6 X R0.2	7	50	100	6								
4CREG 060 003 200	6 X R0.3	7	20	60	6								
4CREG 060 003 400	6 X R0.3	7	40	80	6								
4CREG 060 003 500	6 X R0.3	7	50	100	6								
4CREG 060 005 200	6 X R0.5	7	20	60	6								
4CREG 060 005 400	6 X R0.5	7	40	80	6								
4CREG 060 005 500	6 X R0.5	7	50	100	6								
4CREG 060 010 200	6 X R1	7	20	60	6								
4CREG 060 010 400	6 X R1	7	40	80	6								
4CREG 060 010 500	6 X R1	7	50	100	6								
4CREG 060 015 200	6 X R1.5	7	20	60	6								
4CREG 060 015 400	6 X R1.5	7	40	80	6								
4CREG 060 015 500	6 X R1.5	7	50	100	6								
4CREG 080 002 220	8 X R0.2	9	22	65	8								
4CREG 080 003 220	8 X R0.3	9	22	65	8								
4CREG 080 005 220	8 X R0.5	9	22	65	8								
4CREG 080 005 400	8 X R0.5	9	40	100	8								
4CREG 080 010 220	8 X R1	9	22	65	8								
4CREG 080 010 400	8 X R1	9	40	100	8								
4CREG 080 015 220	8 X R1.5	9	22	65	8								
4CREG 080 015400	8 X R1.5	9	40	100	8								
4CREG 080 020 220	8 X R2	9	22	65	8								
4CREG 100 002 240	10 X R0.2	11	24	70	10								
4CREG 100 003 240	10 X R0.3	11	24	70	10								
4CREG 100 005 240	10 X R0.5	11	24	70	10								
4CREG 100 005 400	10 X R0.5	11	40	100	10								
4CREG 100 010 240	10 X R1	11	24	70	10								
4CREG 100 010 400	10 X R1	11	40	100	10								

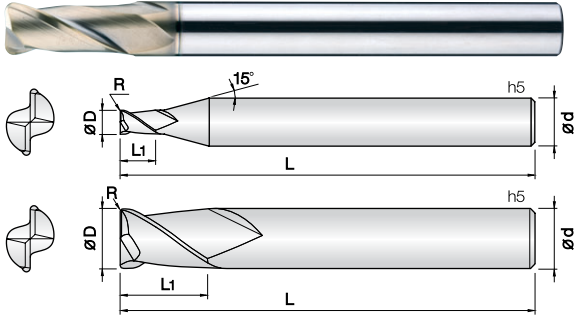

- 중저경도강(HRC52이하), 프리하트강 계열, 탄소강, 금형강 등 가공
- JCRO 코팅 처리하여 넓은 영역의 피삭재 가공에 적합합니다.
- 고정밀 공차 적용으로 초정밀 가공에 적합합니다.
- 코너R 형상을 날부치핑이 적도록 설계하였습니다.
- 다양한 코너R과 전장으로 맞춤 가공이 가능합니다.
- 항절력이 높은 미립자 초경합금(0.5 μ m)을 채택, 엔드밀의 파손을 최소화
- **Endmills for various work materials(~HRC52), pre-hardened steel, carbon steel, mold steel.**
- Optimum for various work materials by JCRO coating.
- High precise edge tolerance.
- Designed for minimizing edge chipping by corner R shape.
- Various corner R and overall length for wide range application.
- Minimize fracturing by high TRS fine(0.5 μ m) WC grade.



D Size	D Tolerance
Ø0.4 ~ 5	+0 ~ -0.01mm
Ø6 ~ 12	-0.005 ~ -0.015mm

단위 : mm

Order Number	날경 Diameter D×R	날장 Length of cut L1	전장 Overall Length L	생크 Shank Dia d	비고	Order Number	날경 Diameter D×R	날장 Length of cut L1	전장 Overall Length L	생크 Shank Dia d	비고
2NCRG 004 0005 S04	0.4 X R0.05	0.8	45	4		2NCRG 040 005 080	4 X R0.5	9	80	4	
2NCRG 004 001 S04	0.4 X R0.1	0.8	45	4		2NCRG 040 005 S06	4 X R0.5	10	70	6	
2NCRG 005 0005 S04	0.5 X R0.05	1	45	4		2NCRG 040 010 060	4 X R1	9	60	4	
2NCRG 005 001 S04	0.5 X R0.1	1	45	4		2NCRG 040 010 080	4 X R1	9	80	4	
2NCRG 006 0005 S04	0.6 X R0.05	1.2	45	4		2NCRG 040 010 S06	4 X R1	10	70	6	
2NCRG 006 001 S04	0.6 X R0.1	1.2	45	4		2NCRG 050 001 S06	5 X R0.1	13	75	6	
2NCRG 006 002 S04	0.6 X R0.2	1.2	45	4		2NCRG 050 002 S06	5 X R0.2	13	75	6	
2NCRG 007 0005 S04	0.7 X R0.05	1.4	45	4		2NCRG 050 003 S06	5 X R0.3	13	75	6	
2NCRG 007 001 S04	0.7 X R0.1	1.4	45	4		2NCRG 050 005 S06	5 X R0.5	13	75	6	
2NCRG 007 002 S04	0.7 X R0.2	1.4	45	4		2NCRG 050 010 S06	5 X R1	13	75	6	
2NCRG 008 0005 S04	0.8 X R0.05	1.6	45	4		2NCRG 060 001 060	6 X R0.1	11	60	6	
2NCRG 008 001 S04	0.8 X R0.1	1.6	45	4		2NCRG 060 001 090	6 X R0.1	13	90	6	
2NCRG 008 002 S04	0.8 X R0.2	1.6	45	4		2NCRG 060 002 060	6 X R0.2	11	60	6	
2NCRG 009 0005 S04	0.9 X R0.05	1.8	45	4		2NCRG 060 002 090	6 X R0.2	13	90	6	
2NCRG 009 001 S04	0.9 X R0.1	1.8	45	4		2NCRG 060 003 060	6 X R0.3	11	60	6	
2NCRG 010 001 S04	1 X R0.1	2.5	45	4		2NCRG 060 003 090	6 X R0.3	13	90	6	
2NCRG 010 002 S04	1 X R0.2	2.5	45	4		2NCRG 060 005 060	6 X R0.5	11	60	6	
2NCRG 010 003 S04	1 X R0.3	2.5	45	4		2NCRG 060 005 090	6 X R0.5	13	90	6	
2NCRG 012 001 S04	1.2 X R0.1	3.2	45	4		2NCRG 060 010 060	6 X R1	11	60	6	
2NCRG 012 002 S04	1.2 X R0.2	3.2	45	4		2NCRG 060 010 090	6 X R1	13	90	6	
2NCRG 012 003 S04	1.2 X R0.3	3.2	45	4		2NCRG 060 015 060	6 X R1.5	11	60	6	
2NCRG 015 001 S04	1.5 X R0.1	4	45	4		2NCRG 060 015 090	6 X R1.5	13	90	6	
2NCRG 015 002 S04	1.5 X R0.2	4	45	4		2NCRG 060 020 060	6 X R2	11	60	6	
2NCRG 015 003 S04	1.5 X R0.3	4	45	4		2NCRG 060 020 090	6 X R2	13	90	6	
2NCRG 015 005 S04	1.5 X R0.5	4	45	4		2NCRG 060 025 090	6 X R2.5	13	90	6	
2NCRG 020 001 S04	2 X R0.1	6	45	4		2NCRG 080 001 070	8 X R0.1	16	70	8	
2NCRG 020 002 S04	2 X R0.2	6	45	4		2NCRG 080 001 100	8 X R0.1	19	100	8	
2NCRG 020 003 S04	2 X R0.3	6	45	4		2NCRG 080 002 070	8 X R0.2	16	70	8	
2NCRG 020 005 S04	2 X R0.5	6	45	4		2NCRG 080 002 100	8 X R0.2	19	100	8	
2NCRG 025 001 S04	2.5 X R0.1	6	50	4		2NCRG 080 003 070	8 X R0.3	16	70	8	
2NCRG 025 002 S04	2.5 X R0.2	6	50	4		2NCRG 080 003 100	8 X R0.3	19	100	8	
2NCRG 025 003 S04	2.5 X R0.3	6	50	4		2NCRG 080 005 070	8 X R0.5	16	70	8	
2NCRG 025 005 S04	2.5 X R0.5	6	50	4		2NCRG 080 005 100	8 X R0.5	19	100	8	
2NCRG 030 001 S06	3 X R0.1	8	60	6		2NCRG 080 005 120	8 X R0.5	19	120	8	
2NCRG 030 002 S06	3 X R0.2	8	60	6		2NCRG 080 010 070	8 X R1	16	70	8	
2NCRG 030 003 S06	3 X R0.3	8	60	6		2NCRG 080 010 100	8 X R1	19	100	8	
2NCRG 030 005 S06	3 X R0.5	8	60	6		2NCRG 080 010 120	8 X R1	19	120	8	
2NCRG 030 010 S06	3 X R1	8	60	6		2NCRG 080 015 070	8 X R1.5	16	70	8	
2NCRG 040 001 060	4 X R0.1	9	60	4		2NCRG 080 015 100	8 X R1.5	19	100	8	
2NCRG 040 001 080	4 X R0.1	9	80	4		2NCRG 080 020 070	8 X R2	16	70	8	
2NCRG 040 001 S06	4 X R0.1	10	70	6		2NCRG 080 020 100	8 X R2	19	100	8	
2NCRG 040 002 060	4 X R0.2	9	60	4		2NCRG 080 025 100	8 X R2.5	19	100	8	
2NCRG 040 002 080	4 X R0.2	9	80	4		2NCRG 080 030 100	8 X R3	19	100	8	
2NCRG 040 002 S06	4 X R0.2	10	70	6		2NCRG 080 035 100	8 X R3.5	19	100	8	
2NCRG 040 003 060	4 X R0.3	9	60	4		2NCRG 100 001 075	10 X R0.1	19	75	10	
2NCRG 040 003 080	4 X R0.3	9	80	4		2NCRG 100 001 100	10 X R0.1	22	100	10	
2NCRG 040 003 S06	4 X R0.3	10	70	6		2NCRG 100 002 075	10 X R0.2	19	75	10	
2NCRG 040 005 060	4 X R0.5	9	60	4		2NCRG 100 002 100	10 X R0.2	22	100	10	

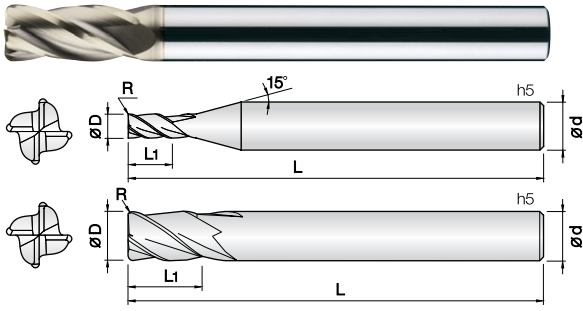

- 중저경도강(HRc52이하), 프리하든강 계열, 탄소강, 금형강 등 가공
- JCRO 코팅 처리하여 넓은 영역의 피삭재 가공에 적합합니다.
- 고정밀 공차 적용으로 초정밀 가공에 적합합니다.
- 코너 R 형상을 날부치핑이 적도록 설계하였습니다.
- 다양한 코너R과 전장으로 맞춤 가공이 가능합니다.
- 항절력이 높은 미립자 초경합금(0.5 μ m)을 채택, 엔드밀의 파손을 최소화
- **Endmills for various work materials(~HRc52), pre-hardened steel, carbon steel, mold steel.**
- Optimum for various work materials by JCRO coating.
- High precise edge tolerance.
- Designed for minimizing edge chipping by corner R shape.
- Various corner R and overall length for wide range application.
- Minimize fracturing by high TRS fine(0.5 μ m) WC grade.



D Size	D Tolerance
ø1 ~ 5	+0 ~ -0.01mm
ø6 ~ 12	-0.005 ~ -0.015mm
ø16	-0.01 ~ -0.02mm

단위 : mm

Order Number	날경 Diameter D×R	날장 Length of cut L1	전장 Overall Length L	생크 Shank Dia d	비고	Order Number	날경 Diameter D×R	날장 Length of cut L1	전장 Overall Length L	생크 Shank Dia d	비고
4NCRG 010 0005 S04	1 X R0.05	2.5	45	4		4NCRG 060 003 080	6 X R0.3	13	80	6	
4NCRG 010 001 S04	1 X R0.1	2.5	45	4		4NCRG 060 005 060	6 X R0.5	11	60	6	
4NCRG 010 002 S04	1 X R0.2	2.5	45	4		4NCRG 060 005 080	6 X R0.5	13	80	6	
4NCRG 010 003 S04	1 X R0.3	2.5	45	4		4NCRG 060 010 060	6 X R1	11	60	6	
4NCRG 015 0005 S04	1.5 X R0.05	4	45	4		4NCRG 060 010 080	6 X R1	13	80	6	
4NCRG 015 001 S04	1.5 X R0.1	4	45	4		4NCRG 060 015 060	6 X R1.5	11	60	6	
4NCRG 015 002 S04	1.5 X R0.2	4	45	4		4NCRG 060 015 080	6 X R1.5	13	80	6	
4NCRG 015 003 S04	1.5 X R0.3	4	45	4		4NCRG 060 020 060	6 X R2	11	60	6	
4NCRG 015 005 S04	1.5 X R0.5	4	45	4		4NCRG 060 020 080	6 X R2	13	80	6	
4NCRG 020 0005 S04	2 X R0.05	6	45	4		4NCRG 080 001 070	8 X R0.1	16	70	8	
4NCRG 020 001 S04	2 X R0.1	6	45	4		4NCRG 080 001 090	8 X R0.1	19	90	8	
4NCRG 020 002 S04	2 X R0.2	6	45	4		4NCRG 080 002 070	8 X R0.2	16	70	8	
4NCRG 020 003 S04	2 X R0.3	6	45	4		4NCRG 080 002 090	8 X R0.2	19	90	8	
4NCRG 020 005 S04	2 X R0.5	6	45	4		4NCRG 080 003 070	8 X R0.3	16	70	8	
4NCRG 025 001 S04	2.5 X R0.1	6	50	4		4NCRG 080 003 090	8 X R0.3	19	90	8	
4NCRG 025 002 S04	2.5 X R0.2	6	50	4		4NCRG 080 005 070	8 X R0.5	16	70	8	
4NCRG 025 003 S04	2.5 X R0.3	6	50	4		4NCRG 080 005 090	8 X R0.5	19	90	8	
4NCRG 025 005 S04	2.5 X R0.5	6	50	4		4NCRG 080 005 110	8 X R0.5	19	110	8	
4NCRG 030 001 S06	3 X R0.1	8	60	6		4NCRG 080 010 070	8 X R1	16	70	8	
4NCRG 030 002 S06	3 X R0.2	8	60	6		4NCRG 080 010 090	8 X R1	19	90	8	
4NCRG 030 003 S06	3 X R0.3	8	60	6		4NCRG 080 010 110	8 X R1	19	110	8	
4NCRG 030 005 S06	3 X R0.5	8	60	6		4NCRG 080 015 070	8 X R1.5	16	70	8	
4NCRG 030 010 S06	3 X R1	8	60	6		4NCRG 080 015 090	8 X R1.5	19	90	8	
4NCRG 040 001 060	4 X R0.1	9	60	4		4NCRG 080 015 110	8 X R1.5	19	110	8	
4NCRG 040 001 080	4 X R0.1	9	80	4		4NCRG 080 020 070	8 X R2	16	70	8	
4NCRG 040 001 S06	4 X R0.1	10	70	6		4NCRG 080 020 090	8 X R2	19	90	8	
4NCRG 040 002 060	4 X R0.2	9	60	4		4NCRG 080 020 110	8 X R2	19	110	8	
4NCRG 040 002 080	4 X R0.2	9	80	4		4NCRG 080 025 090	8 X R2.5	19	90	8	
4NCRG 040 002 S06	4 X R0.2	10	70	6		4NCRG 100 001 075	10 X R0.1	19	75	10	
4NCRG 040 003 060	4 X R0.3	9	60	4		4NCRG 100 001 100	10 X R0.1	22	100	10	
4NCRG 040 003 080	4 X R0.3	9	80	4		4NCRG 100 002 075	10 X R0.2	19	75	10	
4NCRG 040 003 S06	4 X R0.3	10	70	6		4NCRG 100 002 100	10 X R0.2	22	100	10	
4NCRG 040 005 060	4 X R0.5	9	60	4		4NCRG 100 003 075	10 X R0.3	19	75	10	
4NCRG 040 005 080	4 X R0.5	9	80	4		4NCRG 100 003 100	10 X R0.3	22	100	10	
4NCRG 040 005 S06	4 X R0.5	10	70	6		4NCRG 100 005 075	10 X R0.5	19	75	10	
4NCRG 040 010 060	4 X R1	9	60	4		4NCRG 100 005 100	10 X R0.5	22	100	10	
4NCRG 040 010 080	4 X R1	9	80	4		4NCRG 100 005 120	10 X R0.5	22	120	10	
4NCRG 040 010 S06	4 X R1	10	70	6		4NCRG 100 010 075	10 X R1	19	75	10	
4NCRG 050 001 S06	5 X R0.1	13	75	6		4NCRG 100 010 100	10 X R1	22	100	10	
4NCRG 050 002 S06	5 X R0.2	13	75	6		4NCRG 100 010 120	10 X R1	22	120	10	
4NCRG 050 003 S06	5 X R0.3	13	75	6		4NCRG 100 015 075	10 X R1.5	19	75	10	
4NCRG 050 005 S06	5 X R0.5	13	75	6		4NCRG 100 015 100	10 X R1.5	22	100	10	
4NCRG 050 010 S06	5 X R1	13	75	6		4NCRG 100 015 120	10 X R1.5	22	120	10	
4NCRG 060 001 060	6 X R0.1	11	60	6		4NCRG 100 020 075	10 X R2	19	75	10	
4NCRG 060 001 080	6 X R0.1	13	80	6		4NCRG 100 020 100	10 X R2	22	100	10	
4NCRG 060 002 060	6 X R0.2	11	60	6		4NCRG 100 020 120	10 X R2	22	120	10	
4NCRG 060 002 080	6 X R0.2	13	80	6		4NCRG 100 025 075	10 X R2.5	19	75	10	
4NCRG 060 003 060	6 X R0.3	11	60	6		4NCRG 100 025 100	10 X R2.5	22	100	10	

3&4날 범용 45° 헬릭스 파인피치형 리핑 엔드밀

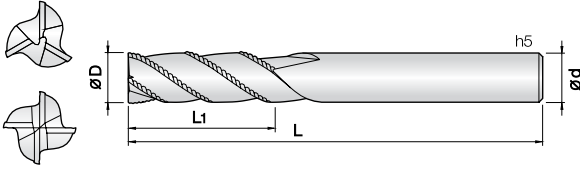

- 합금강, SUS계열, 인코넬, 일반구조강 등 다양한 난삭재의 황삭가공
- JCRO 코팅 처리하여 다양한 피삭재 가공시 인선부에 스트레스가 적으며, 내마모성 또한 향상됩니다.
- 45° 헬릭스 적용으로 절삭 저항이 감소되어 장시간 가공에 적합합니다.
- 파인피치 형상 채택으로 고속, 황삭가공 작업에 적합합니다.
- **Roughing Endmills for hard to cut materials, alloy steel, SUS, Inconel and structural steel.**
- JCRO coating provides wear resistance improvement as well as avoid edge stress in various applications.
- Long tool life with low cutting force by 45° degree helix design.
- Fine pitch shape design for high speed roughing application.

3

4

WC
마립자

JCRO
Coating

DI
-0.02 -0.04

DI
-0.02 -0.05

45°
Helix Angle

Shield Edge

D Size	D Tolerance
ø4 ~ 9	0.02~ -0.04mm
ø10 ~ 20	0.02~ -0.05mm

Order Number	날경 Diameter D	날장 Length of cut L1	전장 Overall Length L	생크 Shank Dia d	비고															
3HROUG 040 100 S06	4	10	50	6																
3HROUG 050 130 S06	5	13	50	6																
3HROUG 060 100 050	6	10	50	6																
3HROUG 060 160 055	6	16	55	6																
3HROUG 060 200 060	6	20	60	6																
3HROUG 070 180 S08	7	18	65	8																
3HROUG 080 120 060	8	12	60	8																
3HROUG 080 190 065	8	19	65	8																
3HROUG 080 250 070	8	25	70	8																
4HROUG 090 220 S10	9	22	70	10																
4HROUG 100 150 070	10	15	70	10																
4HROUG 100 220 070	10	22	70	10																
4HROUG 100 300 080	10	30	80	10																
4HROUG 110 270 S12	11	27	80	12																
4HROUG 120 200 075	12	20	75	12																
4HROUG 120 250 080	12	25	80	12																
4HROUG 120 350 090	12	35	90	12																
4HROUG 160 320 090	16	32	90	16																
4HROUG 160 400 110	16	40	110	16																
4HROUG 200 380 110	20	38	110	20																
4HROUG 200 500 120	20	50	120	20																

단위 : mm

G series